

INTELLISPEC™

Diverter

Pressco Technology Inc.

71577 Rev. 02



Addendum

© 2014 Pressco Technology Inc. All rights reserved.

No part of this manual may be reproduced or transmitted in any form or by any means, electronic or mechanical, including photocopying and recording, for any purpose, without the express written permission of Pressco Technology Inc.

The contents of this manual are furnished for informational use only, are subject to change without notice, and should not be construed as a commitment by Pressco Technology Inc.

Written and designed at:

Pressco Technology Inc. World Headquarters

29200 Aurora Road

Cleveland, OH USA 44139-1847

TEL 440-498-2600

FAX 440-498-2615

www.pressco.com

Table of Contents

Chapter 1 Safety Information and Markings	3
Warning Symbol.....	3
Residual Risk	3
Intended Use.....	4
Non-intended use	5
Personal Protective Equipment	5
Personnel Safety	6
Lifting heavy objects	7
Authorized Users.....	8
Spare Parts Usage	8
Chapter 2 Installation and Initial Checks	9
Electrical Connections.....	9
Air Supply	12
Bottle Detect Sensor and Reflector	13
I/O Check.....	14
Diverter Interface.....	15
Control System.....	15
Segment Check	16
Encoder Parameters	17
Segment Calibration	18
Chapter 3 Bottle Setup	21
New Bottle Type	21
Bottle Distance and Width.....	22
Segment Extension and Retraction Times	24
Maximum Conveying Speed for Segments	26
Chapter 4 Operating Instructions	29
Run Bottles - Normal Operation	29
Part Changeover	31
Chapter 5 Maintenance and Troubleshooting.....	33
Maintenance.....	33
Replacing segments	34
Replacing cylinder sets.....	35
Replacing metal guides for segments	37
Troubleshooting.....	38
Chapter 6 Reject Logic Module (optional).....	39
Why the Reject Logic Module is Required	39
Operation.....	39
Timing Setup Mode.....	40
Chapter 7 Wiring Diagrams.....	43
Diverter Wiring page 1 of 5.....	44
Diverter Wiring page 2a of 5.....	45
Diverter Wiring page 2b of 5.....	46
Diverter Wiring page 3 of 5.....	47

Diverter Wiring page 4 of 5.....	48
Diverter Wiring page 5a of 5.....	48
Diverter Wiring page 5b of 5.....	49
Chapter 8 How to Contact Pressco	51
Index	53

Chapter 1

Safety Information and Markings

This section contains operator safety information that must be read before operating or servicing the system.



Warning

Do not, under any circumstances, tamper with sealed machine parts or devices. This could result in the removal of protections that might create potentially hazardous conditions.



Warning

This product contains no operator serviceable parts. Refer servicing to qualified personnel. To prevent electrical shock do not open cabinet doors whilst power is connected.

Warning Symbol

The following symbols are used on the Diverter product. Be aware of potential risk hazards.



DANGER - Crush Hazard

Keep hands clear while operating. Lock out power before servicing.



Residual Risk

The Intellispec system has been designed to minimize any danger of personal injury. However, the system uses rejection devices to remove defective product from the production stream. Also, the electronics cabinets contain risk of shock if they are opened.

Observe the following safety warnings when operating the system or working near it:



Warning

Potential for projectiles to strike persons and cause injury. Keep clear of reject devices.



Warning

Sensitive electronics and High Voltages may be exposed. Keep Processor Cabinet door closed.

Intended Use

Type of Process

The Intellispec system is intended to monitor container and other special manufacturing processes and identify non-conforming product.

Intended Use

The Intellispec system is designed and constructed for use in an indoor industrial environment, always sheltered from the weather.

Space Required

The Intellispec machine and accompanying sensors must be installed in a place that will enable safe and easy installation, size changeover, user operation, and maintenance procedures.

Non-intended use



Warning

If this instrument is not used as specified, the protection provided by the equipment could be impaired. This instrument must only be used in a normal condition (in which all means of protection are intact).



Important

The Intellispec system should NOT be used for any purpose other than specifically indicated in the section titled *Intended Use* (on page 4).

The following uses are **not** intended:

- Use in an explosive environment
- Use in a flammable environment
- Use in a damp, moist, or wet environment, except where specifically indicated





Personal Protective Equipment



Important

Always follow the safety requirements of your plant in addition to the recommendations below.

We recommend, at minimum, use of the following Personal Protective Equipment (PPE):

	Protective clothing
	Protective gloves
	Protective ear plugs or headphones
	Protective eye wear
	Protective foot wear





Personnel Safety

The following rules are recommended to ensure the safety of personnel in charge of machine operation and maintenance.





Do Not:



- Open safety guards during machine operation
- Perform maintenance and repair while the system is running
- Lean on the machine
- Sit on the machine components
- Use the machine for purposes other than those listed in this manual
- Modify parts of the machine
- Allow unqualified personnel to operate or perform maintenance procedures on the machine

During machine operation:

	Only one operator is needed to operate the machine. All others must keep at a safe distance.
	Operators must be familiar with all machinery connected to the Pressco equipment and know how to use emergency stop devices. <i>Note: the emergency stop devices may not be connected directly to the Pressco equipment, but it is important to know how to use them.</i>
	Before putting the Pressco system online, the operator must ensure that all safety devices used with all connected machinery are in place and operational.
	The operator must maintain maximum focus on his work and be alert throughout his shift. If this is not the case, immediately inform the shift supervisor.

When conducting maintenance or repair work:

	Follow the Machine Maintenance Lockout Procedure.
	Before starting the machine, ensure that no person is close to the machine.
	If maintenance or repair requires the disconnection or removal of safety or protection systems, authorized personnel who ensure the prevention of personal injury or damage to the machine must supervise this operation. All machine movements must be performed with limited speed and limited movements.
	Exclusively authorized and trained personnel must carry out maintenance or repair work on electrical components. When running tests with power connected, you must strictly comply with the rules provided.

	<p>Personnel working on higher parts of a machine must wear a harness and hook it on to a structure and must always move with extreme caution. The harness must not be connected to Pressco equipment or structure as it cannot support body weight.</p>
	<p>Never perform lubrication or maintenance procedures on mechanical parts with the machine running.</p>

Lifting heavy objects



Caution

Some components are heavy. Take proper precautions to prevent personal injury or damage to equipment. If you are not capable of lifting the object alone, ask a capable person to help lift the object, or use a mechanical lifting device

The components do not have handles to lift the equipment. Be sure to:

- Lift equipment from the bottom - do not use wires, brackets, nor other protrusions
- Keep fingers away from sensor lenses to keep the equipment clean
- Proceed slowly

➤ *To safely lift equipment:*



Caution

Do not twist your body when moving the load. Instead take small steps with your feet turning until you are in the correct position.

1. Stand close to the load and center yourself over it with your feet shoulder width apart.
2. Tighten your abdominal muscles.
3. Keeping your back straight, bend your knees and squat down to the floor.
4. Get a good grasp on the load with both hands.
5. Keeping the load close to your body, use your leg muscles to stand up lifting the load off the floor.
 - Your back should remain straight throughout lifting, using only the muscles in the legs to lift the load.
6. To place the load in the appropriate spot, bend at the knees using only your leg muscles to lower the load.

Authorized Users

Trained machine operators, mechanic and electrical maintenance staff, and plant managers are considered authorized users of the Intellispec system. These users should carefully read the information contained in this manual. The plant manager must ensure that the safety recommendations included in this manual are observed.



Warning

Allowing workers who are unfamiliar with the production process to operate the Intellispec system could result in hazard risk.

If you are unclear about any part of this manual, **contact Pressco Technical Support** (see "**How to Contact Pressco**" on page 51).



Important

No worker should ever operate the system outside of his/ her own area of competence and responsibility.

Proper Operation:

Only one worker is to operate the system at any given time. The correct position for the operator is in front of the user interface monitor or control enclosure (if applicable).

Repairs:

Any repair on the system shall be carried out exclusively by Pressco Technology Inc. service personnel or by other service expressly authorized by Pressco Technology Inc.

Spare Parts Usage

The following restrictions apply to replacing parts:



Warning

Using spare parts that are not designed to Pressco's specifications can compromise the safety and effectiveness of the Intellispec system.

- The use of parts that are not within Pressco's design specifications is prohibited. This prohibition applies in particular when the parts involved contain or are connected with safety devices.
- Before resuming production, make sure all safety devices are in working order.

Pressco Technology Inc. shall not be liable in any way if any of the above-described directions are not complied with.

To obtain a spare parts list, contact the customer service department at Pressco. **How to Contact Pressco** (on page 51).

Pressco's technicians are available to help customers, in their own plant, to solve any problem that might arise during use and maintenance of the Intellispec system.

Chapter 2

Installation and Initial Checks

Electrical Connections

Make electrical connections per Pressco drawings (supplied with the system). Reference the following drawings:

- **Encoder Connection to Diverter** (on page 10)
- **Results Connection to Diverter** (on page 11)

❖ *Note: All signals must share a common voltage source.*



Important

A ground terminal is available, but it is already grounded through the diverter. Do not connect a ground wire to this terminal, unless the diverter is temporarily installed in such a way that it is not in contact with a grounded object, such as a conveyor frame.

The shield of the encoder cable may be connected to this terminal, provided it is not already grounded at its other end. The encoder cable shield must be properly grounded; otherwise the diverter may start behaving erratically at high speed.

Encoder Connection to Diverter

ENCODER CONNECTION TO DIVERTER

SOLUTION WHEN JUST A CABLE SPLITTER IS USED.
 NOTE: THIS IS JUST AN EXAMPLE. DIFFERENT ENCODERS AND MODULES MAY WARRANT DIFFERENT CABLES.

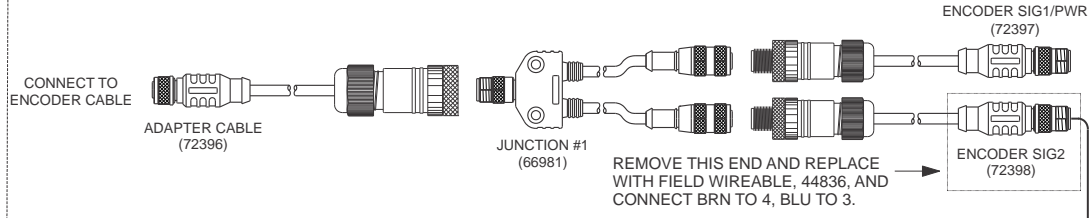

ENCODER SPLITTER BOX, 70787.
 REFERENCE 70787Q FOR DETAILED CONNECTION INFORMATION.

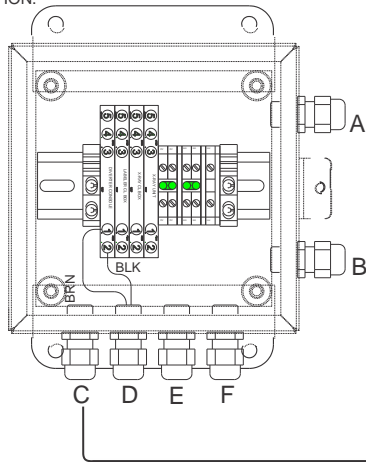

SOLUTION WHEN THE ENCODER SPLITTER BOX IS USED

- PORTS USED:
- PORT A=TO ENCODER
 - B=TO FHCP3X ENCODER PORT
 - C=TO DIVERTER CONSOLE ENCODER PORT
 - D=TO LABELER CL-BOX ENCODER PORT
 - E=TO X-RAY CL-BOX ENCODER PORT
 - F=TO X-RAY UNIT ENCODER PORT

CONNECT FLYING LEAD END OF STANDARD M12 MALE CABLE, 70691, AS FOLLOWS:
 BRN TO TERM 1, BLK TO TERM 2.

UNDERSIDE OF DIVERTER CONSOLE

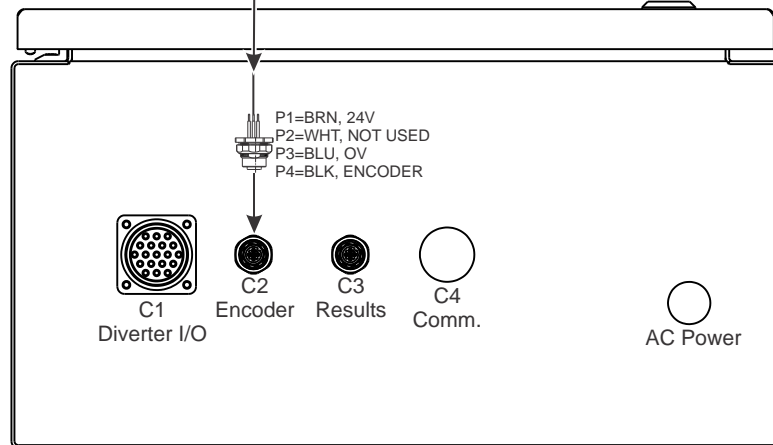

Results Connection to Diverter

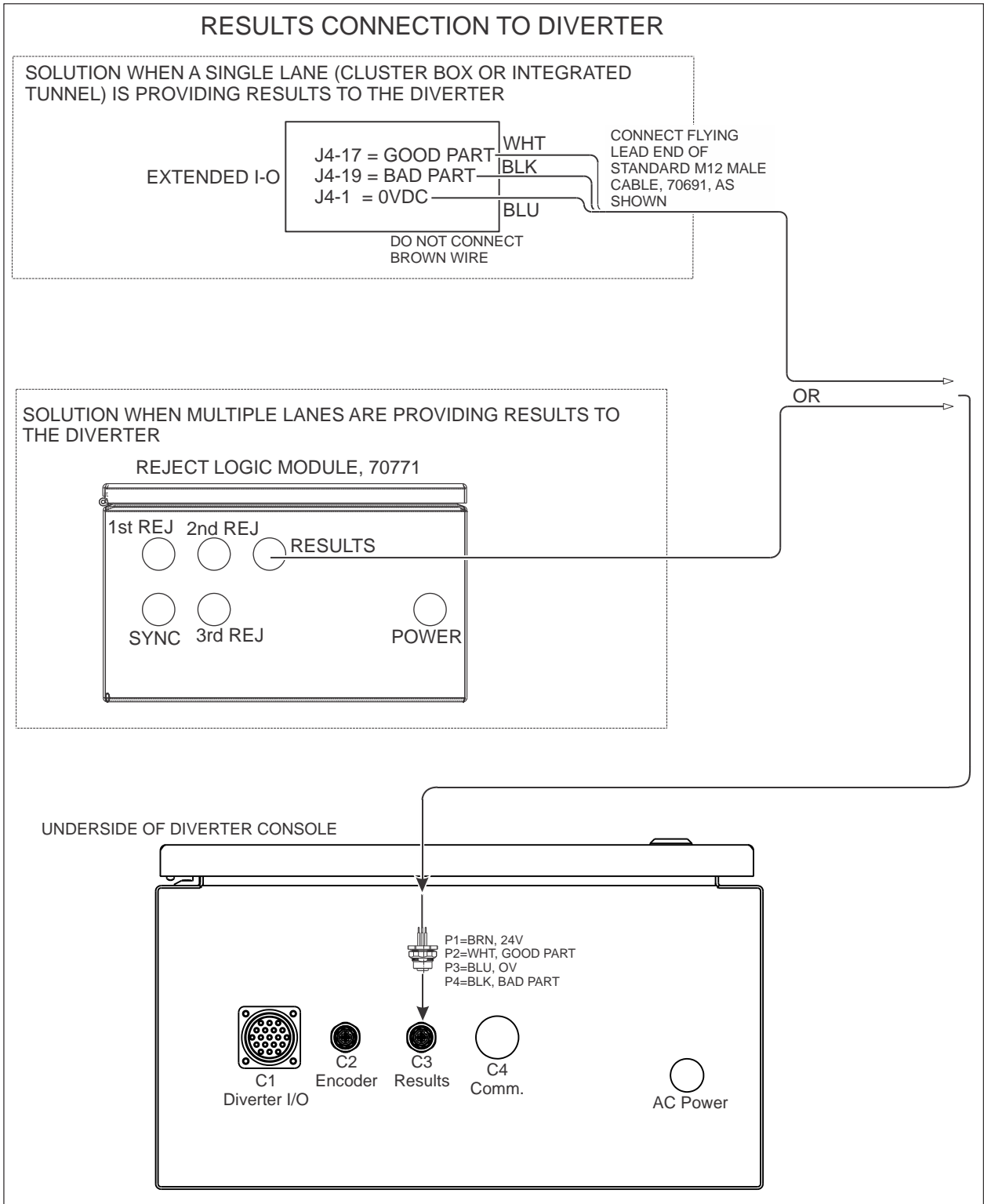

Air Supply

Connect plant air supply where indicated below. Make sure it runs at 50 PSI.

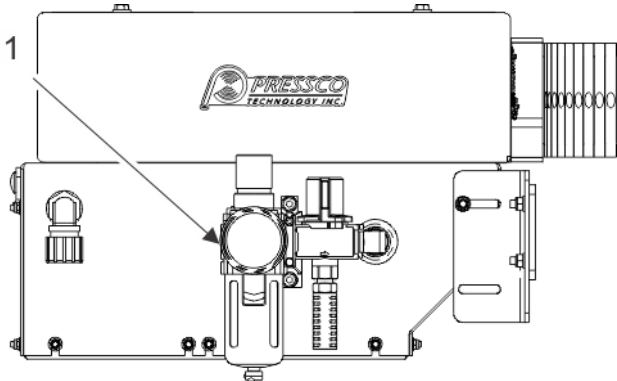

1	Air supply connection
---	-----------------------

Bottle Detect Sensor and Reflector

A reflector must be present across the conveyor from the product detection photocell. This reflector must be relatively narrow in the conveying direction to maximize the accuracy (5mm is considered reasonable; a wider reflector may be partially masked with tape if necessary).

An error message will be displayed if the product is detected at the diverter before an inspection result signal is received. The same error message will be displayed if the photocell fails to detect the reflector.

Mount the reflector on the opposite side of the conveyor from the diverter as shown below.

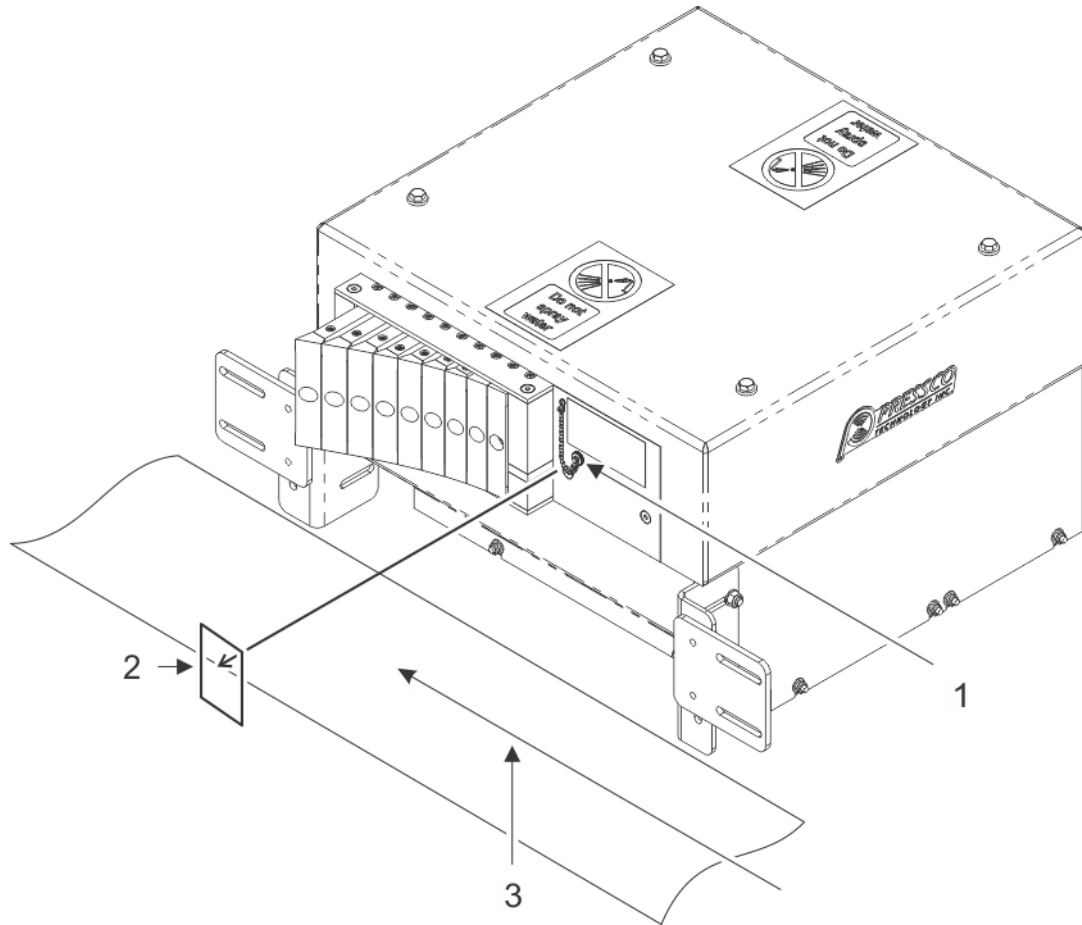

1	Bottle detect sensor. A cap is present to prevent water from entering.
2	Bottle detect reflector
3	Conveyor; part flow direction



❖ *Note: The sensor cap shown above [item 1] is normally installed. Remove it only during **Bottle Distance and Width** (on page 22) calibration, then replace the cap.*

I/O Check

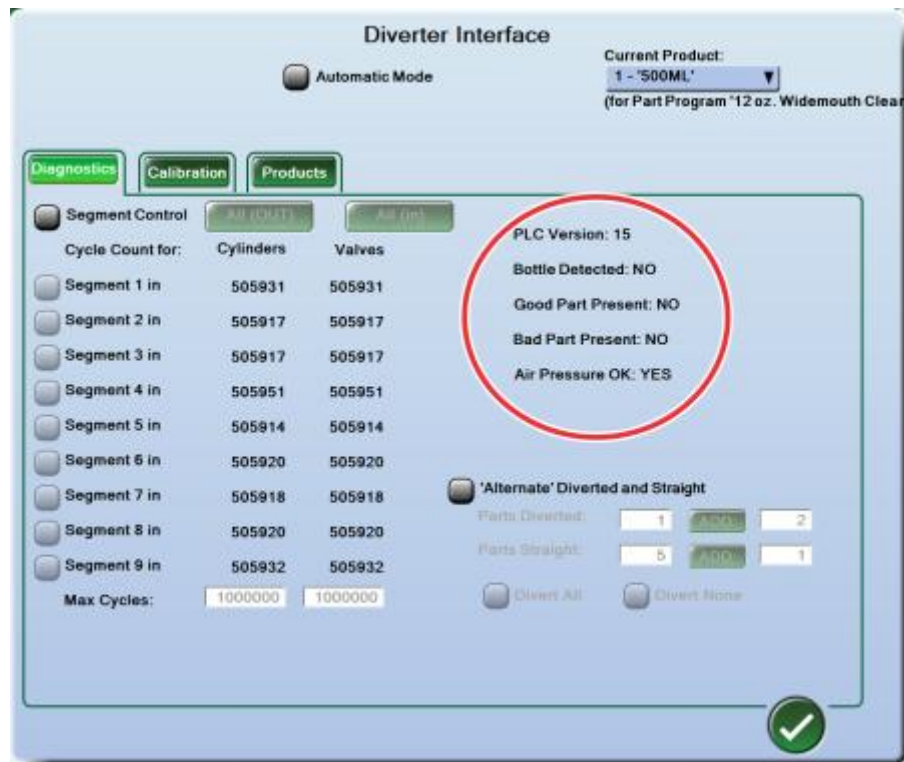
Verify the proper operation of the I/O signals before operating the unit.



➤ To check I/O:

1. Go to the Diverter interface: From Lane Overview or Sensor Overview mode, select the Tools button , then **Hardware Setup**, then **Diverter Interface**.
2. At the top the diverter user interface, make sure the **Automatic Mode** box is **un-checked**.
3. With the **Diagnostics** tab selected, verify the **Good Part Present** and **Bad Part Present** signals. Check these by putting good parts and bad parts through the Intellispec inspection tunnel. These signals come from the Pressco Intellispec system, or a Pressco Reject Logic Module (if applicable). If your system has a Pressco Reject Logic Module, verify proper connection and operation of this module.
4. Verify the **Bottle Detected** signal. This signal is received from the photocell (in the diverter module) located just before the segments. You can block the beam with your hand or another object to see the I/O signal change on the screen.
5. Verify that the air pressure is OK. We suggest temporarily turning off the air supply and then turning it back on to see the I/O signal change on the screen.
6. Select the OK button  to save changes and exit.

Diverter Interface

This topic provides a brief overview of the diverter software interface. The common items are shown below.

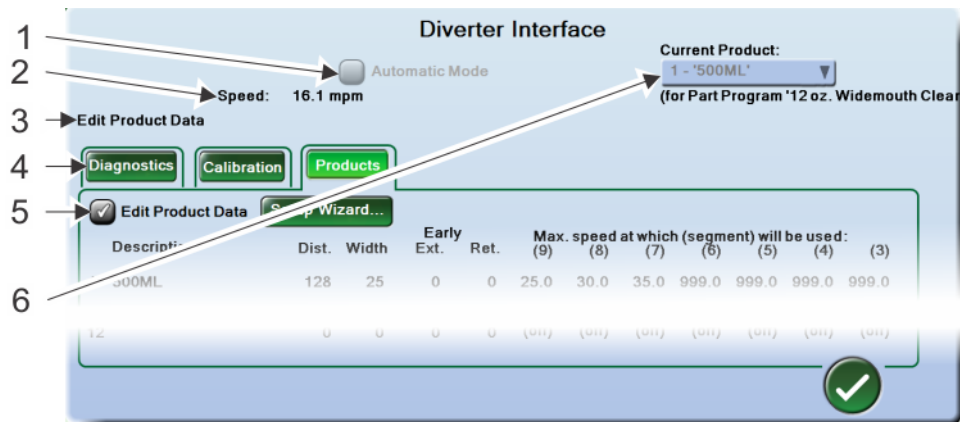

1	The Automatic Mode box is checked during normal run operation. See Run Bottles - Normal Operation (on page 29). The box is unchecked and becomes unavailable if you are performing maintenance or setup.
2	On some screens, you can see current conveyor speed. mpm = meters per minute; fpm = feet per minute
3	If you see text as shown, it indicates which main text box under a tab is currently selected [item 5]. You will not be able to change items under another tab.
4	Three tabs provide functions for the Diverter, used in different setup and operational procedures.
5	The main check box under each tab enables the functions for the currently selected tab. If one is selected, then you will not be able to change items in another tab or use Automatic mode.
6	The current product is selected through a drop-down menu. You must set up bottles for them to appear in the drop-down list. The Intellispec part program keeps track of the diverter product number selected for it, and automatically switches to that product number when the part program is loaded. See Part Changeover (on page 31)

Control System

The control system contains a programmable logic controller (PLC).

The PLC program is proprietary and is password-protected. The program will stay in memory for approximately 200 days without power. If the battery is removed from the PLC, the program may disappear after five days. Therefore, keep the battery in the PLC.

The Intellispec controls the values in the PLC and sets the diverter's mode of operation. Once in Automatic mode, the PLC will stay in that mode indefinitely.

The PLC must be connected and in run mode for the Intellispec Diverter Interface to work properly.

Segment Check

Test each of the segments to determine proper operation.



Warning

The diverter segments will be extended during this procedure. Keep your hands and body away from the front of the diverter during testing. Physical injury may result.

➤ To test the segments:

1. Go to the Diverter interface: From Lane Overview or Sensor Overview mode, select the Tools button , then **Hardware Setup**, then **Diverter Interface**.
2. At the top the diverter user interface, make sure the **Automatic Mode** box is **un-checked**.
3. On the **Diagnostics** tab [item 1], check the **Segment Control** box [item 2]. (see illustration below)
4. Test each segment individually: Check **Segment 1** [item 3] in the menu and make sure segment 1 is extended.
5. Check **Segment 2** on the menu and make sure segment 2 is extended.
6. Repeat step 4 for segments 3 through 9.
7. Look at the **Segment Detected** status [item 6] to make sure it works correctly. There is a photocell located at the rear of the segments to determine whether the segments are retracted or not. It will say "NO" if all segments are out.
8. Select the **All (Out)** or **All (in)** buttons [items 4 and 5] to move all segments at once.
9. Retract all segments before exiting this menu: click the **All (in)** [item 5] button.
10. Un-check the Segment Control box to disable Segment Control (so that you can enable other functions).

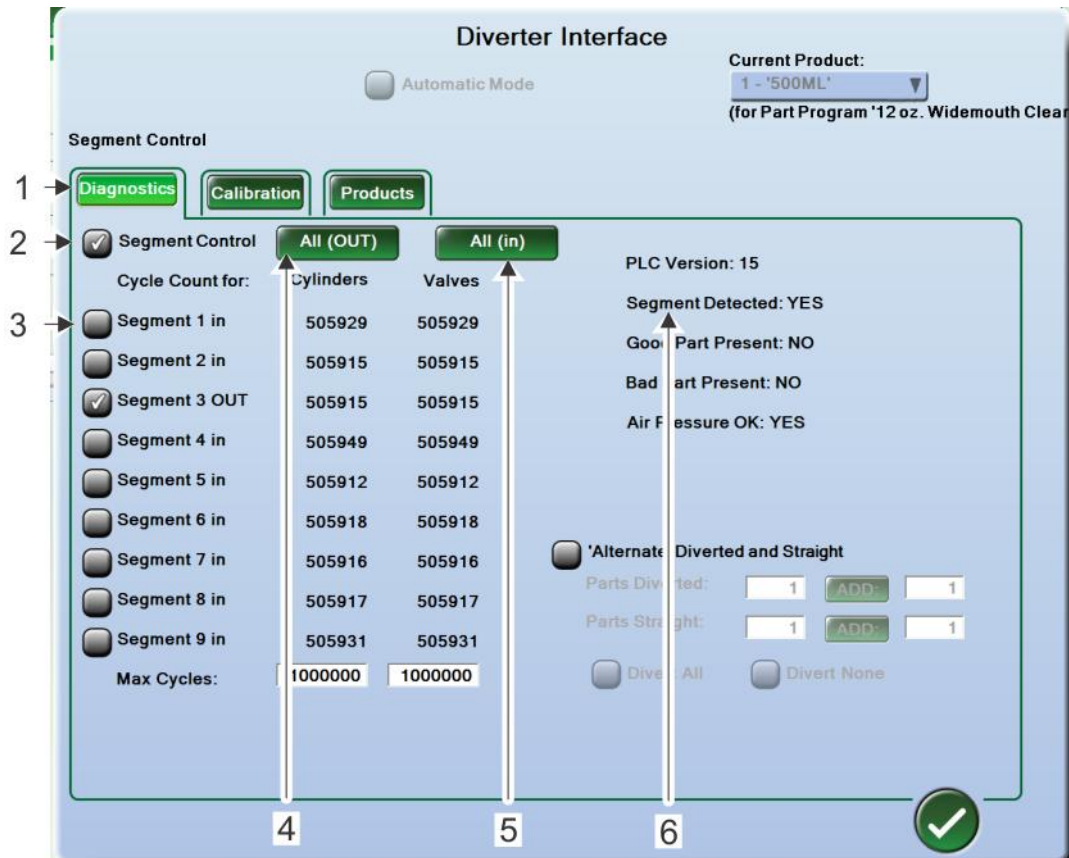



1	Tab for diagnostics functions
2	Enables the functions on this tab
3	Check or un-check box to extend or retract segment
4	Extend all segments at once
5	Retract all segments at once
6	Status of photocell that detects whether segments are extended or retracted. <ul style="list-style-type: none"> ▪ YES = any segment is in ▪ NO = all segments are out

Encoder Parameters

❖ *Note: These numbers are determined by Pressco Engineering based on encoder and conveyor specifications. This number should be set during installation, and should normally not need to be changed.*

➤ To set the encoder parameters:

1. Go to the Diverter interface: From Lane Overview or Sensor Overview mode, select the Tools button , then **Hardware Setup**, then **Diverter Interface**.
2. At the top the diverter user interface, make sure the **Automatic Mode** box is **un-checked**.
3. Select the **Calibration** tab on the Diverter Interface.
4. In the box for **Pulses Per Shift**, enter the number 13 (or another number as determined by Pressco Engineering). This sets the number of encoder pulses per register shift, based on hardware specifications.
5. Select the OK button  to save changes and exit.

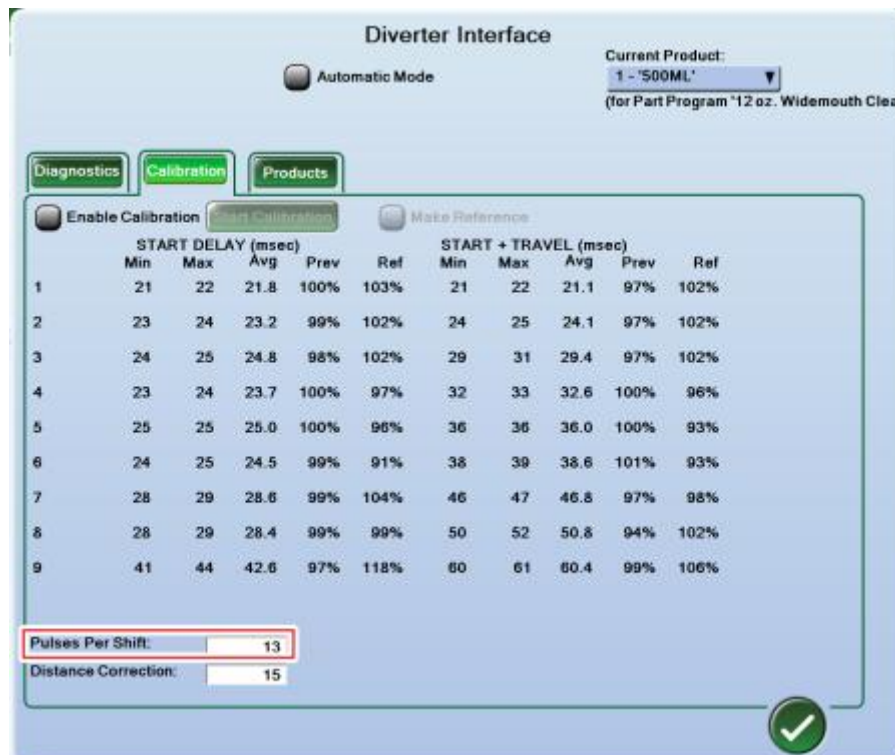

Segment Calibration

This procedure needs to be done after installation. It must also be repeated if something changes on the machine, such as air pressure, or friction between the segments due to wear and tear. The data gathered through this procedure optimizes the diverter's ability to adjust to different conveyor speeds. With wrong or obsolete timing data, the diverter may perform poorly or not at all.

❖ *Note: if your plant's air supply fluctuates frequently, you may need to check segment calibration daily or weekly. Compare the current results to the "Ref" values in this screen.*

The calibration data is hardware-related. It affects the diverter's performance for all products. The best results can only be obtained using the data gathered through this procedure; you cannot adjust the data manually.

The diverter has a photocell and reflector mounted at the back of the segments. It looks across the back of the segments. The active segments will extend at the beginning of the procedure, and it is expected that the photocell beam will become unobstructed as a result. If the beam is still obstructed after the segments are extended, an error message is displayed.

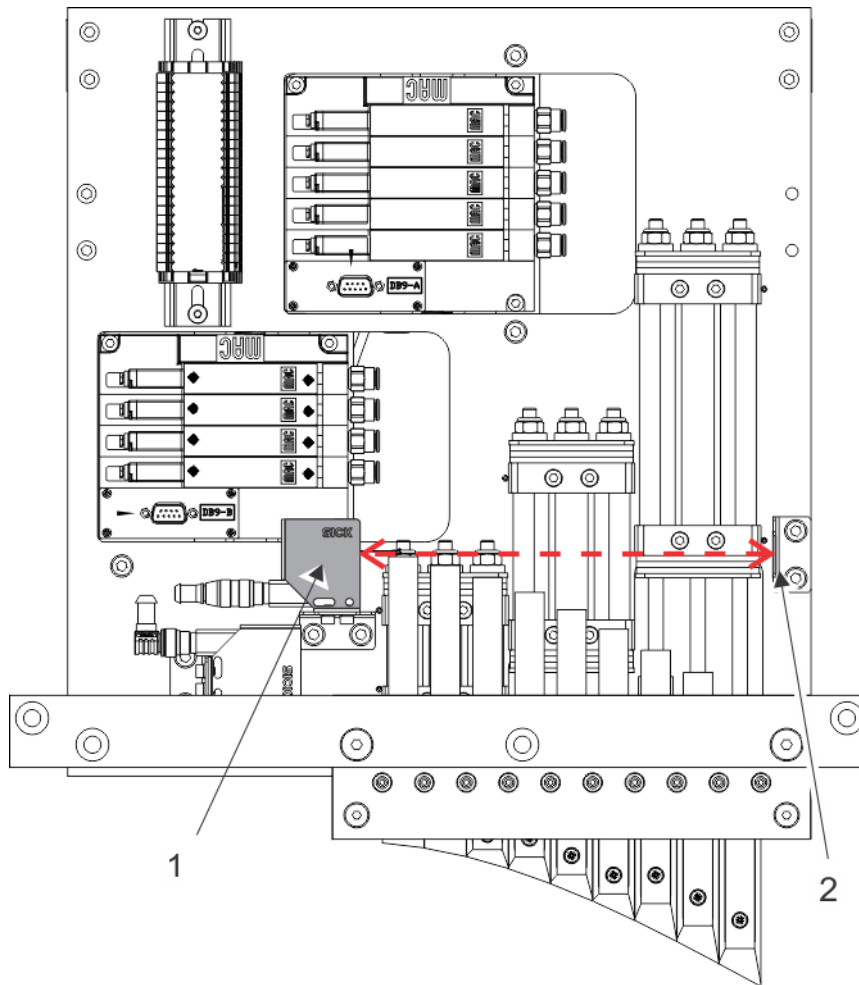



1	Photocell
2	Reflector



Warning

The diverter segments will be extended during this procedure. Keep your hands and body away from the front of the diverter during testing. Physical injury may result.

➤ *To calibrate the diverter segments:*

1. Go to the Diverter interface: From Lane Overview or Sensor Overview mode, select the Tools button , then **Hardware Setup**, then **Diverter Interface**.
2. At the top the diverter user interface, make sure the **Automatic Mode** box is **un-checked**.
3. Under the **Calibration** tab, check the **Enable Calibration** box. All segments are extended.
4. Select the **Start Calibration** button to begin the calibration. The diverter segments will extend and retract 10 times each, while the status is displayed at the top of the screen (Calibrating xx%).
5. Verify that the results are consistent. That is, the Min/ Max/ Avg values should gradually increase from the first to last segment. (see example below).
 - Compare the **Prev** to **Ref** values. These represent the values from the Prev (previous) time you calibrated the segments and the Ref (Make Reference) values.
 - If the values are consistent, then check the **Make Reference** box (if desired). This saves the current values to memory. Note: the system only saves one setting - you do not need to check this every time.
 - Select the **Accept** button to continue. Then select the **OK** button to continue.
 - If the values are incorrect, such as values of zero, or an obviously incorrect number, then troubleshoot the segments. See: **Troubleshooting** (on page 38).
 - If you choose **not** to accept the results, then:
 - Un-check the **Enable Calibration** box. This discards the current readings, and allows you to repeat the calibration.
 - Check the **Enable Calibration** box again. Select the **Start Calibration** button to repeat the process, and make adjustments or troubleshoot until the calibration results are acceptable.
6. After you have accepted the results, un-check the **Enable Calibration** box. This allows you to enable other features in the Diverter interface.
7. Select the OK button  to save changes and exit.

After segment calibration, the system is ready for **bottle setup** (on page 21) and operation.

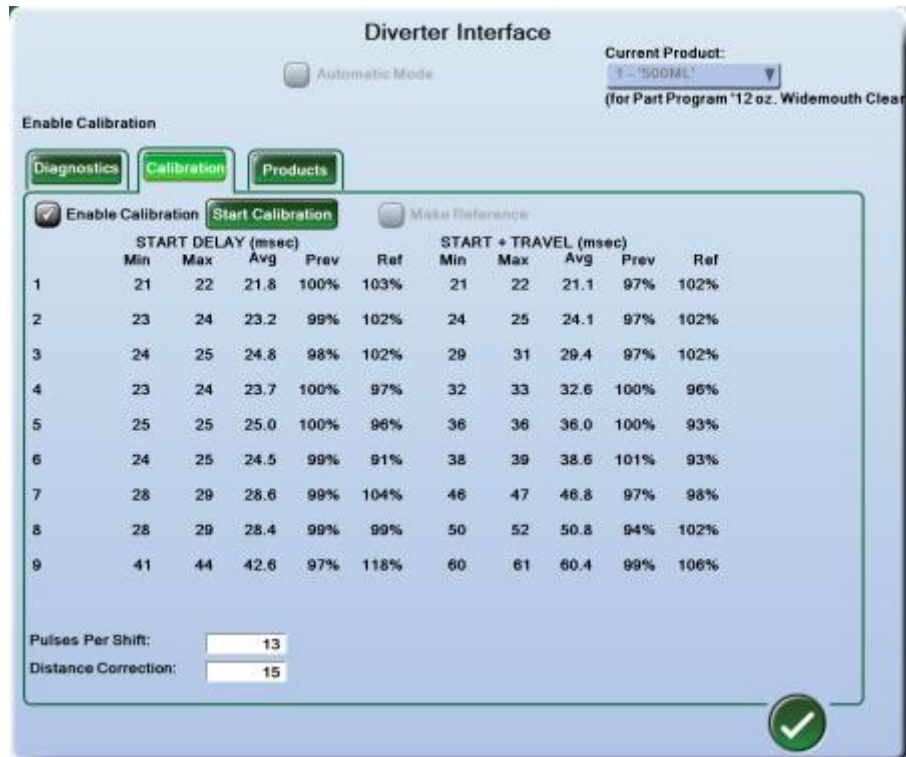

Once the calibration is completed, two sets of results are displayed as **times** and **percentages**.

- One set of results is the **start delay** for each segment. This is the time (in milliseconds) between the moment a signal is sent to extend a segment, and the moment the segment actually leaves its retracted position.
- The other set of results displays each **start** and **travel** time, including the **start delay** above.
- When the data is displayed as a **percentage**, the results are compared with the values obtained the last time the procedure was performed, as well as with the memorized reference values. Any set of results may be saved as reference values for the future.
- **Prev** (previous) values show the difference between the current calibration and the last time you ran calibration.
- **Ref** (reference) values show the difference between the current calibration and the last time you checked and saved **Make Reference**.

Chapter 3

Bottle Setup

This section contains instructions to set up a new bottle. The procedures should be performed in the order shown below.

➤ **Before setting up a new bottle:**

Verify that the following checks have been performed. Normally these are done during installation. If any component has been moved or replaced, then perform the following checks.

1. Verify that proper **electrical connections** (on page 9) are made
2. Verify that proper **Air Supply** (on page 11) connections are made
3. Verify proper I/O operation through the **I/O check** (on page 14)
4. Verify that all the diverter segments are working through the **Segment Check** (on page 15)
5. Verify that the **Encoder Parameters** (on page 17) are correct
6. Verify that **Segment Calibration** (on page 18) has been performed

➤ **To set up a new bottle, perform the following procedures in this order:**

1. **New Bottle Type** (on page 21)
2. **Bottle Distance and Width** (on page 22)
3. **Segment Extension and Retraction Times** (on page 24)
4. **Maximum Conveying Speed for Segments** (on page 26)



➤ **For normal operation (after you have set up bottles), see** Run Bottles - Normal Operation (on page 29).

➤ **If you already have bottles set up and want to switch to a different part, see** Part Changeover (on page 31).

New Bottle Type

A product must be defined and activated for the diverter to be able to run in automatic mode. Up to 12 different bottle types can be defined. These are stored in the diverter's PLC.

➤ **To assign a name to a new bottle type:**

1. Go to the Diverter interface: From Lane Overview or Sensor Overview mode, select the Tools button , then **Hardware Setup**, then **Diverter Interface**.
2. At the top the diverter user interface, make sure the **Automatic Mode** box is **un-checked**.
3. Select the **Products** tab in the Diverter Interface.
4. Check the **Edit Product Data** box. This allows you to enter and change bottle information.
5. Select the **Setup Wizard** button. The Wizard provides tools for naming and setting up a bottle.
6. In the Wizard Step 1 screen, select a bottle number from the drop-down menu. The diverter allows a maximum of 12 bottle types to be set up.
7. Select the Next arrow  to continue.
8. In the Wizard Step 2 screen, name the product you are inspecting. A keyboard is displayed for you to enter a description.
9. Enter up to 10 characters as a description and select the Next arrow to continue, or the OK button  to save and exit. Note that if more than 10 characters are entered, all characters are discarded.

Next, set up **Bottle Distance and Width** (on page 22).

Bottle Distance and Width

This procedure computes the distance between the place on the conveyor where the Intellispec initiates a "result" signal and the diverter itself. It also computes the part width.

❖ *Note: it is critical that containers always be in the exact same position when an inspection result is sent, regardless of whether inspection times are constant or variable. That is, there should be no part slippage.*

➤ **What you need before using the product dimensions measurement tool:**

- A running conveyor that will transport a bottle from upstream of the inspection system to the diverter. We recommend using a low conveying speed for best results.
- An Intellispec inspection system set up to pass or reject bottles. Load the correct Intellispec Part Program for the current bottle you are inspecting.
- Your bottle must be named in the Diverter interface, in addition to the Intellispec Part Program: **Assign a Name to a New Bottle Type** (see "**New Bottle Type**" on page 21)
- If your system has a Pressco Reject Logic Module, make sure that it has been correctly calibrated, and is in production mode. **Reject Logic Module (optional)** (on page 39)
- A few bottles to run through the inspection system on the conveyor. Put only one bottle on the conveyor at a time while performing this procedure.

❖ *Note: the calibration sensor does not sense clear objects. We recommend that you place a piece of opaque tape around clear or non-opaque bottles at the height of the photocell for this procedure so that the photocell cannot see through it.*

❖ *To improve target accuracy, place tape on the reflector opposite the sensor to create a 5mm wide sensing target. Refer to illustration: **Bottle Detect Sensor and Reflector** (on page 12).*

➤ **To measure the distance and width:**

1. Before entering the Diverter interface, put the Intellispec lane online.
2. Remove the cap from the sensor on the front of the Diverter. Refer to [item 1] **Bottle Detect Sensor and Reflector** (on page 12).
3. Run the conveyor, at a slow speed, with one bottle. The bottle should pass through/by the Intellispec inspection module, and the Intellispec should generate a signal to pass or reject (divert) a bottle. It does not matter which signal is sent.
4. Go to the Diverter interface: From Lane Overview or Sensor Overview mode, select the Tools button , then **Hardware Setup**, then **Diverter Interface**.
5. At the top the diverter user interface, make sure the **Automatic Mode** box is **un-checked**.
6. Select the **Products** tab, check the **Edit Product Data** box, and select the **Setup Wizard** button. The Wizard is displayed.

- On the left side of the Wizard, select the **Product Dimensions** button. (You can jump to any step in the Wizard at any time)

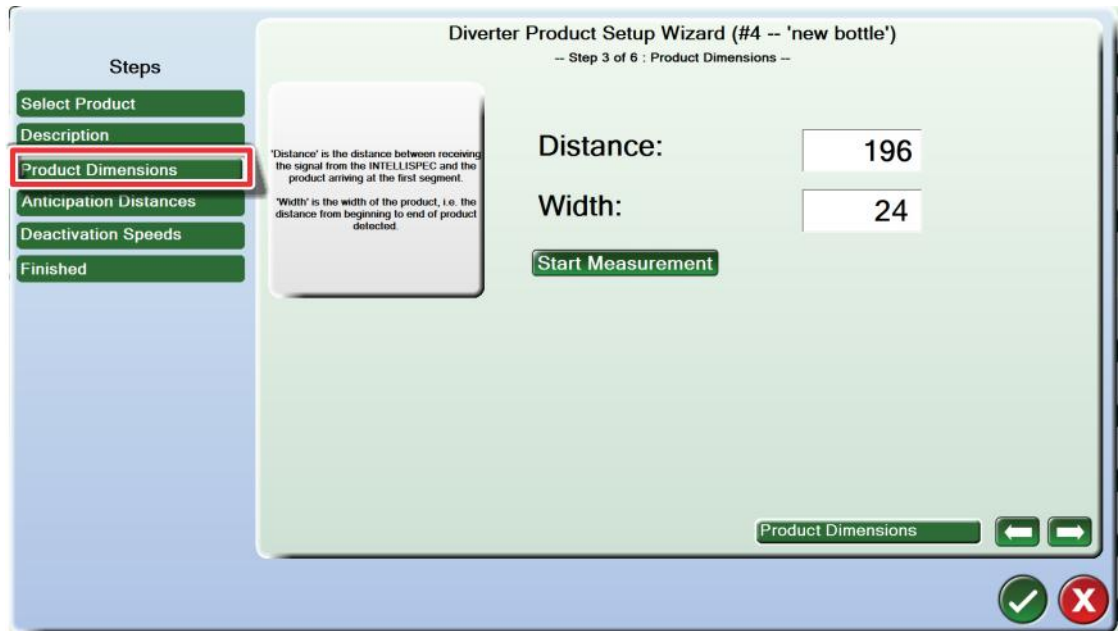

- Select the **Start Measurement** button. The system steps through 1) Measurement started (waiting), 2) Measured distance (received signal from Intellispec), 3) Measure width (diverter sees bottle's leading edge), and 4) Measurement completed (diverter sees bottle's trailing edge).
- The results are displayed on the screen.
 - Distance** - distance from the place on the conveyor where the pass or reject signal is received to the photocell on the diverter.
 - Width** - bottle width.
 - These numbers are measured in shift register positions. A shift register position = 7/72 inch.
Example: the measurement procedure measures 196 and a width of 24. Distance = $(196 * 7/72)$ = 19.06 inches. Product length = $(24 * 7/72)$ = 2.33 inches.
- Select the Next arrow to continue, or select the OK button  to save the results and exit
- Replace the sensor cap on the front of the Diverter. Refer to [item 1] **Bottle Detect Sensor and Reflector** (on page 12).

❖ *Note: you may want to repeat this procedure a couple of times to make sure that the readings are consistent.*

Next, set the **Segment Extension and Retraction Times** (on page 24).

Segment Extension and Retraction Times

The object of this procedure is to:

- Make sure segments are extended before bad bottles reach them (during normal operation), and
- Make sure segments are not touching good bottles.

These procedures use a very low conveying speed that allows you to observe the position of the bottle with respect to the diverter segments.

❖ *Tip: using a high speed camera to record the segment action can help you determine whether segments are extending and retracting at the correct times.*

➤ To test segment extension and retraction:

1. Before entering the Diverter interface, put the Intellispec lane online.
2. Go to the Diverter interface: From Lane Overview or Sensor Overview mode, select the Tools button , then **Hardware Setup**, then **Diverter Interface**.
3. At the top the diverter user interface, make sure the **Automatic Mode** box is **un-checked**.
4. Under the Diagnostics tab, check the Segment Control box. (You may need to un-check the first box in another tab if was still selected from a different procedure). This allows you to change settings in this screen.
5. Check the box for 'Alternate' Diverted and Straight. This makes sure some bottles are diverted and some are not.
6. Un-check the Segment Control box. This disables segment control, but allows the Alternate mode to operate.
7. Check the **Automatic Mode** box at the top of the screen. The Alternate mode functions become active.

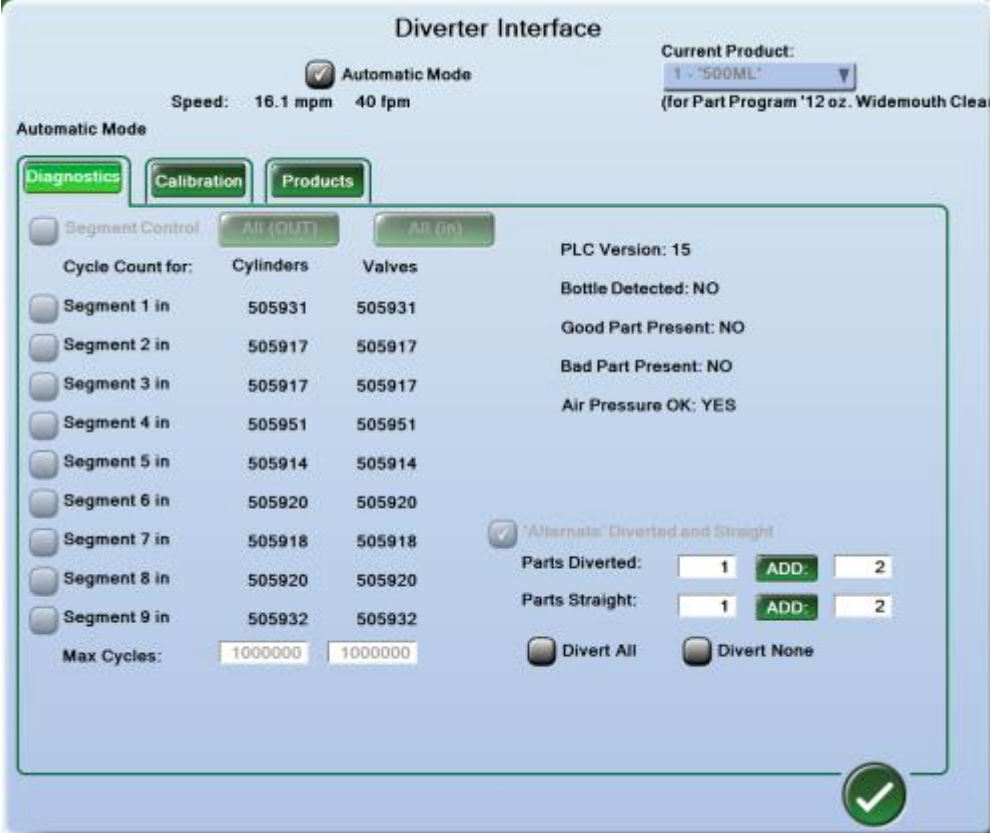

Diverter Interface

Current Product: 1 - 500ML
(for Part Program 12 oz. Widemouth Clear)

Speed: 16.1 mpm 40 fpm

Automatic Mode

Automatic Mode

Diagnostics Calibration Products

Segment Control **All (OUT)** **All (IN)**

Cycle Count for:	Cylinders	Valves
<input type="checkbox"/> Segment 1 in	505931	505931
<input type="checkbox"/> Segment 2 in	505917	505917
<input type="checkbox"/> Segment 3 in	505917	505917
<input type="checkbox"/> Segment 4 in	505951	505951
<input type="checkbox"/> Segment 5 in	505914	505914
<input type="checkbox"/> Segment 6 in	505920	505920
<input type="checkbox"/> Segment 7 in	505918	505918
<input type="checkbox"/> Segment 8 in	505920	505920
<input type="checkbox"/> Segment 9 in	505932	505932

Max Cycles: 1000000 1000000

PLC Version: 15
Bottle Detected: NO
Good Part Present: NO
Bad Part Present: NO
Air Pressure OK: YES

'Alternate' Diverted and Straight

Parts Diverted: 1 **ADD:** 2

Parts Straight: 1 **ADD:** 2

Divert All Divert None

8. Enter the value "1" next to **Parts Diverted** and **Parts Straight**. The diverter will now divert every other bottle.

9. Un-check the Automatic Mode box at the top of the screen. This allows you to use the functions under the tabs.
10. Under the Products tab, select the **Edit Product Data** box, then select the **Setup Wizard** button.
11. Select the **Anticipation Distances** button. (You can jump to any step in the Wizard at any time)
12. Next to Extension, enter the value 15. You may need to adjust this value, but it provides a good value to start.

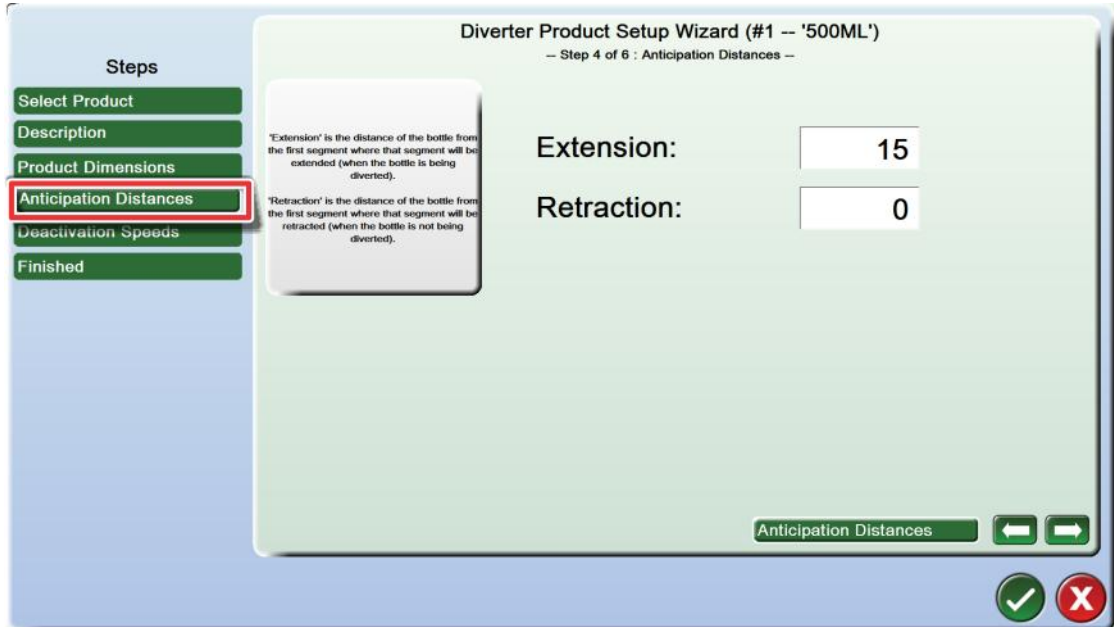

13. Run the conveyor, at a slow speed, with one bottle. The bottle should pass through/by the Intellispec inspection module, and the Intellispec should generate a signal to pass or reject (divert) a bottle. It does not matter which signal is sent. If it is not diverted, send another bottle through. Note that the segments will extend to divert the bottle and stay out. The diverter should receive one signal for each bottle. It is not important which signal is received from the inspection system, only that one signal per bottle is sent. In this mode, the signals will cause the diverter to alternate between "divert" and "straight" modes.
 14. Send another bottle through the system. This time the segments should retract just before the bottle. They must not come in contact with the bottle, but should be very close.
 - a) If one of the segments touches the bottle, you will need to **decrease** the "**Extension**" distance. Keep in mind that the distance is measured in shift register positions, which is roughly equivalent to 0.10 inch. For reference, each segment is 7/8 inch wide.
 - b) If no segment touches the bottle, but it seems that they could have been retracted later without a problem, you can **increase** the "**Retraction**" distance.
 15. Repeat step 14 (the system will alternate between divert and straight) until you are satisfied that the segments extend and retract at the correct times.
 16. Once you are satisfied with the timing, verify the setup further by running four consecutive bottles through the system with a spacing of about 1/2 inch. If there are no timing issues, the setup is complete.
 17. Select the Next arrow to continue, or select the OK button  to save the results and exit.
- Next, set the **Maximum Conveying Speed for Segments** (on page 26).

Maximum Conveying Speed for Segments

This procedure will determine the maximum conveying speed for segments at which they will be extended. At high speeds, it is not necessary to use all segments to divert the bottles. The higher the speed, the lower number of segments is required.

Related topic: **Segment Calibration** (on page 18)

➤ *To determine the maximum conveying speed for each segment:*



Warning

The diverter segments will be extended during this procedure. Keep your hands and body away from the front of the diverter during testing. Physical injury may result.

1. Go to the Diverter interface: From Lane Overview or Sensor Overview mode, select the Tools button , then **Hardware Setup**, then **Diverter Interface**.
2. At the top the diverter user interface, make sure the **Automatic Mode** box is **un-checked**.
3. Under the Diagnostics tab, select the **Segment Control** box. (You may need to un-check the first box in another tab if was still selected from a different procedure). This allows you to change settings in this screen.
4. Extend all segments by selecting the **All Out** button. The segments are extended.
5. Un-check the Segment Control box. This allows you to enable functions in a different screen.
6. Under the Products tab, select the **Edit Product Data** box, then select the **Setup Wizard** button.
7. Select the **Deactivation Speeds** button. (You can jump to any step in the Wizard at any time)

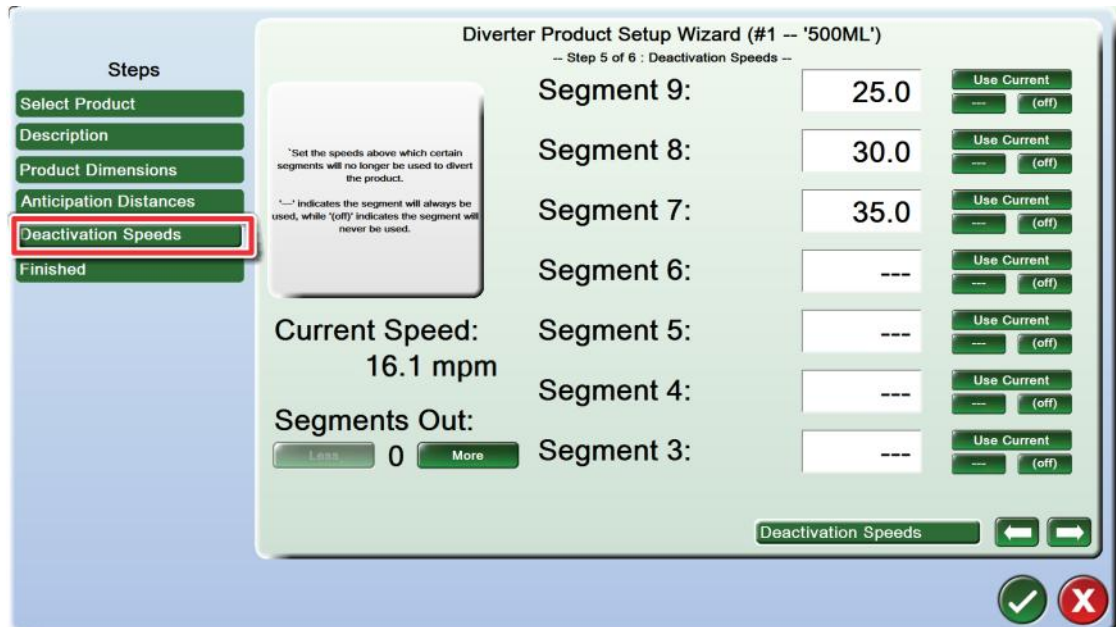

Segment	Speed	Action
Segment 9:	25.0	Use Current (off)
Segment 8:	30.0	Use Current (off)
Segment 7:	35.0	Use Current (off)
Segment 6:	---	Use Current (off)
Segment 5:	---	Use Current (off)
Segment 4:	---	Use Current (off)
Segment 3:	---	Use Current (off)

8. With the conveyor running at a low speed, put one bottle on the conveyor and observe as it is diverted.
9. Put another bottle on the conveyor. Slowly increase the conveyor speed until it becomes necessary to retract the longest segment. That is, the bottle hits the opposite guard rail, falls, or becomes unstable. At the current speed, select the **Use Current** button for Segment 9. Select the **Less** button under Segments Out.

10. Continue to slowly increase the conveyor speed until it becomes necessary to retract the next longest segment. That is, the bottle hits the opposite guard rail, falls, or becomes unstable. At the current speed, select the **Use Current** button for Segment 8. Select the **Less** button under Segments Out.

- ❖ *Tip: for heavy bottles, you may need to retract only the longest segment at the highest speed.*
- ❖ *Note: If you reach your maximum conveying speed at any point during the procedure, then select the "---" button for each of the remaining lower segments.*
- ❖ *Note: The deactivation speed for a segment cannot be lower than a higher numbered segment. That is, deactivation speed for Segment 7 cannot be lower than deactivation speed for Segments 8 and 9.*

11. Repeat step 10 for Segments 7, 6, 5, 4, and 3.

12. Select the Next arrow to continue, or select the OK button  to save the results and exit.

You have completed the bottle setup procedures. The Diverter is ready for standard operation. See **Run Bottles - Normal Operation** (on page 29).

Chapter 4

Operating Instructions

This section contains information about how to operate the diverter after you have set up bottles. It also includes part changeover information.

If you need to set up a new bottle, see **Bottle Setup** (on page 21).

Run Bottles - Normal Operation



The **Automatic** mode is the equipment's standard mode of operation. When in this mode, the diverter's PLC will remain in it indefinitely, even when powered down and back up.

Two different automatic modes are available: Standard mode and **Alternate mode** (on page 29). Both modes use the same input signals; therefore no modification to the wiring is necessary. You select between modes under the Diagnostics tab.

Standard mode

The products for which a "bad" pulse is received are diverted. The bottles for which a "good" pulse is received will not be diverted.

➤ *To place the Diverter in Automatic mode:*

1. Go to the Diverter interface: From Lane Overview or Sensor Overview mode, select the Tools button , then **Hardware Setup**, then **Diverter Interface**.
2. At the top the diverter user interface, make sure the **Automatic Mode** box is **checked**.
3. Select the OK button  to save changes and exit.
4. Put the Intellispec system online to inspect bottles.

Alternate mode

In this mode, the diverter will constantly alternate between the "divert" and "straight" modes. The same inspection result signals as in standard auto mode are used, but only to detect the position of the products, not to determine which products should be diverted. The signal may be wired either to the "good" or "bad" signal terminal, or even to both as long as only one is used for each product.

➤ *To use Alternate mode:*

1. Go to the Diverter interface: From Lane Overview or Sensor Overview mode, select the Tools button , then **Hardware Setup**, then **Diverter Interface**.
2. At the top the diverter user interface, make sure the **Automatic Mode** box is **un-checked**.
3. To change the values for Diverted and Straight modes, refer to the illustration below. Under the Diagnostics tab, check the 'Alternate' Diverted and Straight box [item 3].
4. Check the Automatic mode box [item 1].
5. Change the values for Parts Diverted, Parts Straight [item 4], or Add [item 7].

- Select the OK button  to save changes and exit. The diverter will alternate between Diverted and Straight modes, using the values you saved.

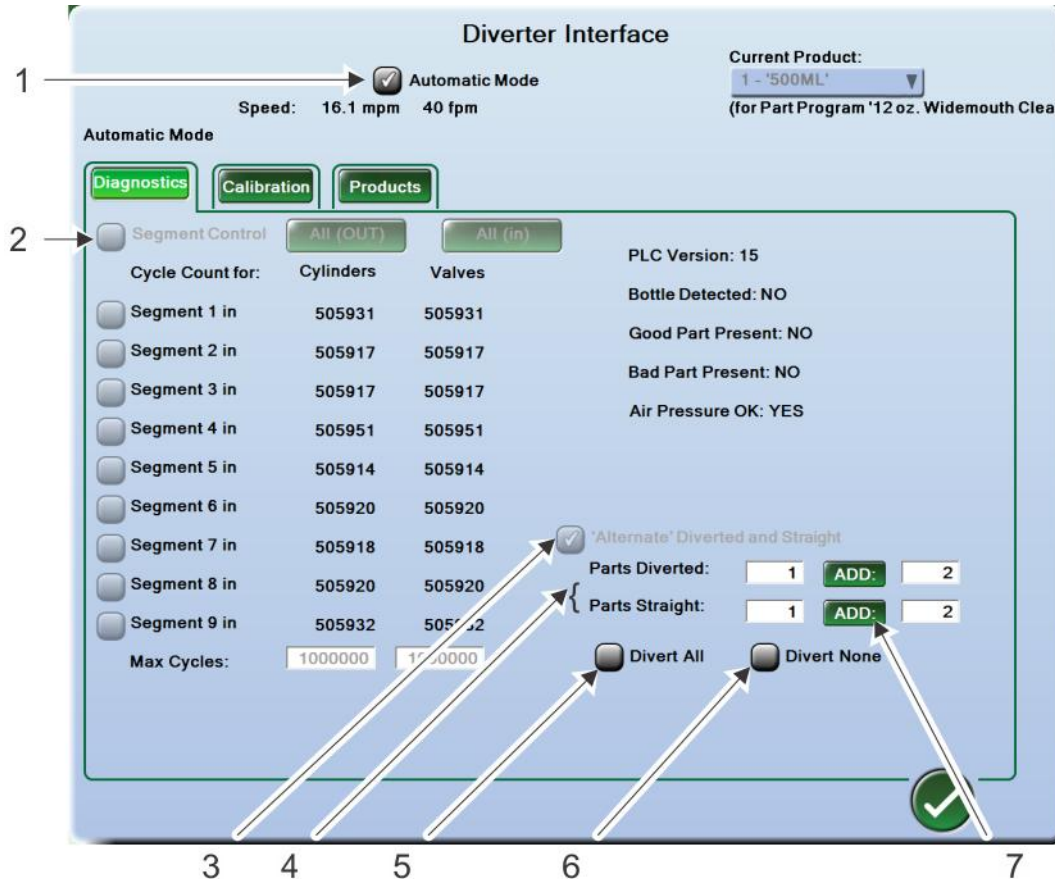



1	Check this box to put diverter in Automatic mode. This disables most functions under all the tabs.
2	Segment Control is grayed out in Automatic mode.
3	Alternate mode must be enabled before putting the diverter into Automatic mode (if you want to use Alternate mode)
4	The number of products for which the current mode is maintained before switching to the other mode.
5	Locks the diverter in this mode, diverting every bottle.
6	Locks the diverter in this mode, diverting no bottles.
7	The value next to the ADD button is added to the Parts Diverted or Parts Straight value only once, and only when you select the ADD button. The purpose is to balance the two sides when required.

➤ **To manually add parts to the Diverted or Straight paths:**

- Make sure the Diverter interface is open, and the diverter is in Alternate mode as described above.
- Select the number of parts you want to divert or go straight [next to item 7], then select the **ADD** button for either path. The number of bottles you have specified will be sent to the selected path, and the diverter will resume Alternate operation.

➤ **To stop using Alternate mode:**

1. Go to the Diverter interface: From Lane Overview or Sensor Overview mode, select the Tools button , then **Hardware Setup**, then **Diverter Interface**.
2. At the top the diverter user interface, make sure the **Automatic Mode** box is **un-checked**.
3. Under the Diagnostics tab, un-check the 'Alternate' Diverted and Straight box. This places the diverter in Standard mode.
4. Select the OK button  to save changes and exit.

Part Changeover



When you switch your production line product, you only need to select the appropriate Intellispec part program. The Intellispec part program keeps track of the diverter product number selected for it, and automatically switches to that product number when the part program is loaded.

When setting up the part program and diverter the first time, you must associate a diverter product with an Intellispec part program.

➤ **To associate a diverter product with an Intellispec part program:**

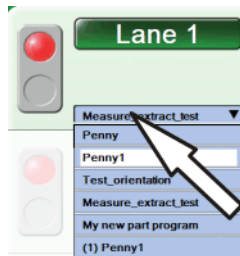
1. From Lane Overview mode, select the part program you want to associate the diverter product with.



2. Go to the Diverter interface: From Lane Overview or Sensor Overview mode, select the Tools button , then **Hardware Setup**, then **Diverter Interface**.
3. At the top the diverter user interface, make sure the **Automatic Mode** box is **un-checked**.
4. From the drop-down menu at the top of the Diverter Interface, selected the Current Product that you are inspecting. The bottle setup must have been completed previously. If you are producing a different bottle, then go through the bottle setup procedures. See **Bottle Setup** (on page 21).
5. Check the Automatic Mode box to enable the diverter to run in standard automatic mode. Or, you may choose to use **Alternate mode** (on page 29).
6. Select the OK button  to save changes and exit.

You are ready to run production using the diverter.

Chapter 5

Maintenance and Troubleshooting

This section contains information to keep your diverter system working well. If you need assistance, contact *Pressco* (see "*How to Contact Pressco*" on page 51).

Maintenance

This section contains information to keep your diverter in properly working order.

The PLC keeps track of the number of times each valve and cylinder is actuated. If a component ever fails, a number of actuations may be entered for similar components. If those components exceed that number of actuations, then the cycle count turns red, and a warning "Maintenance Required" is displayed at the top of the screen. To avoid unnecessary warning messages, initially enter a number that should not be reached for several months.

➤ *To edit the maximum number of cycles:*

1. Go to the Diverter interface: From Lane Overview or Sensor Overview mode, select the Tools button , then **Hardware Setup**, then **Diverter Interface**.
2. At the top the diverter user interface, make sure the **Automatic Mode** box is **un-checked**.
3. Under the Diagnostics tab, check the **Segment Control** box. This allows you to edit the screen.
4. In the fields for Max Cycles for cylinders and valves, enter a number cycles that the system will remind you to maintain them.

Replacing segments

Segments need to be replaced only if they become defective. They normally do not need to be replaced. To replace segments, use a 4mm Allen key and a 7mm wrench, as illustrated below.

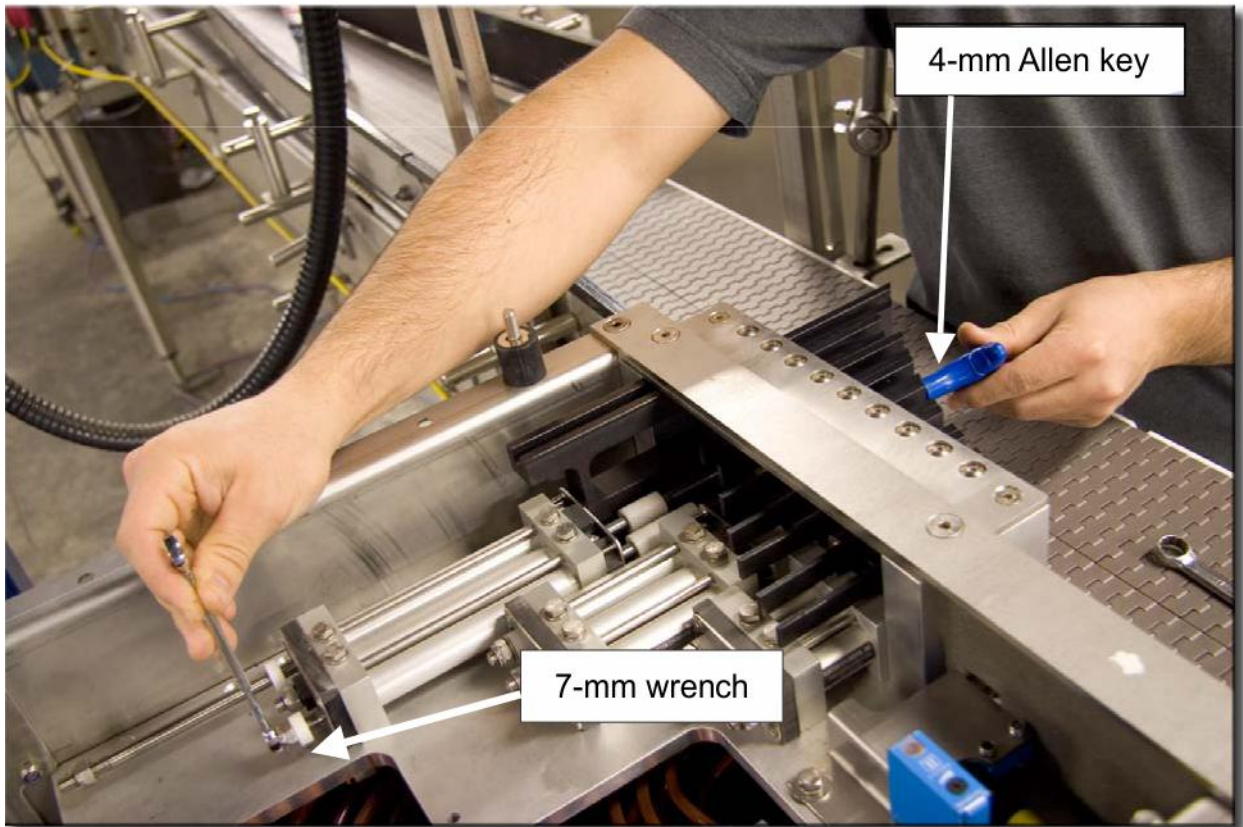

Replacing cylinder sets

Cylinders need to be replaced only if they become defective. They normally do not need to be replaced. There is a segment cycle counter in the **Diverter Interface** (on page 15) that can be cleared if you replace the segment.

➤ **To clear the counter:**

1. Go to the Diverter interface: From Lane Overview or Sensor Overview mode, select the Tools button , then **Hardware Setup**, then **Diverter Interface**.
2. At the top the diverter user interface, make sure the **Automatic Mode** box is **un-checked**.
3. On the **Diagnostics** tab, check the **Segment Control** box.
4. Click one of the cylinder or valve cycle counts on the screen. The Intellispec prompts you with a message to clear the count.
5. Clear the counter.
6. Un-check the Segment Control box to disable Segment Control (so that you can enable other functions).

To replace a set of cylinders, it is not necessary to first remove the segments. However, in the pictures below, the segments have been removed for clarity.

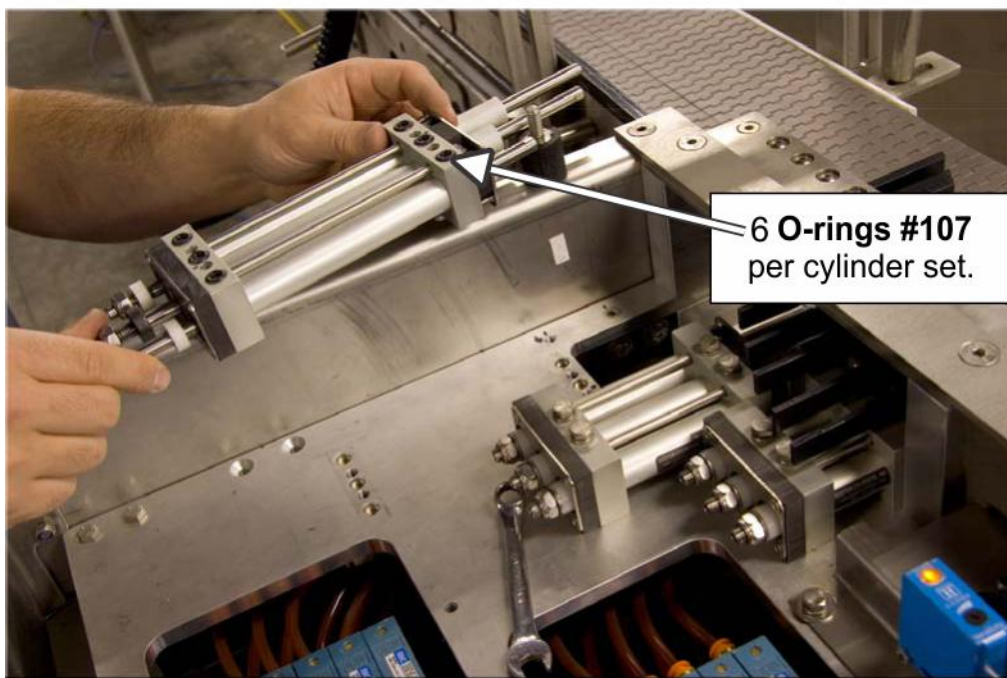
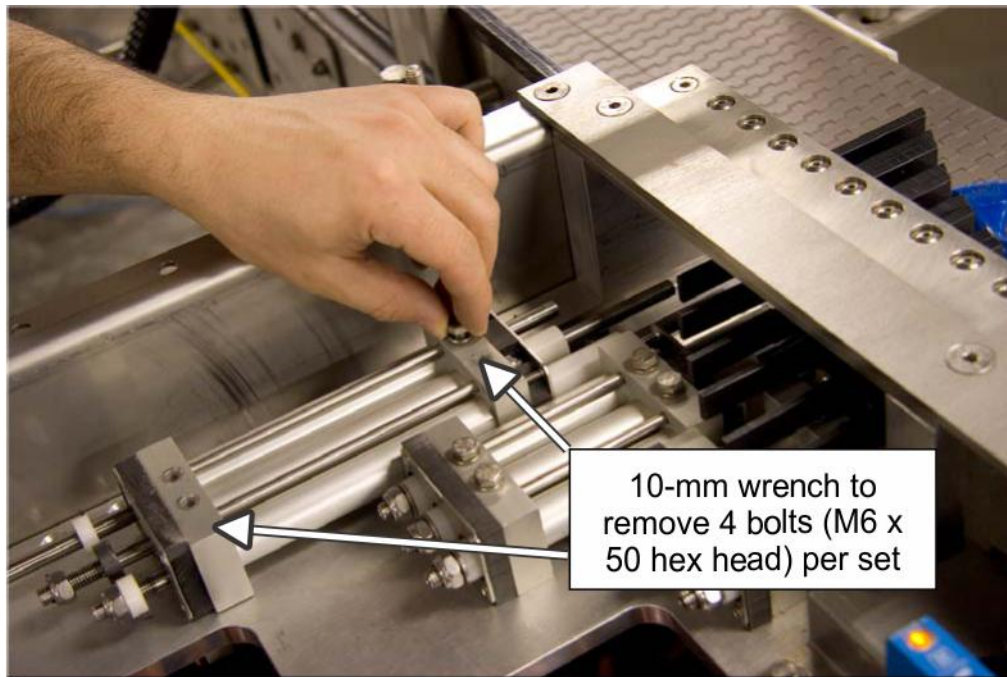

Replacing metal guides for segments

Metal guides need to be replaced only if they become defective. They normally do not need to be replaced.

➤ *To replace the metal guides for segments:*

1. Remove the part using a 5mm Allen key.
2. Remove the top and bottom assemblies using a 5mm Allen key.
3. Replace the parts as necessary.
4. Tighten the assemblies and guides using a 5mm Allen key.

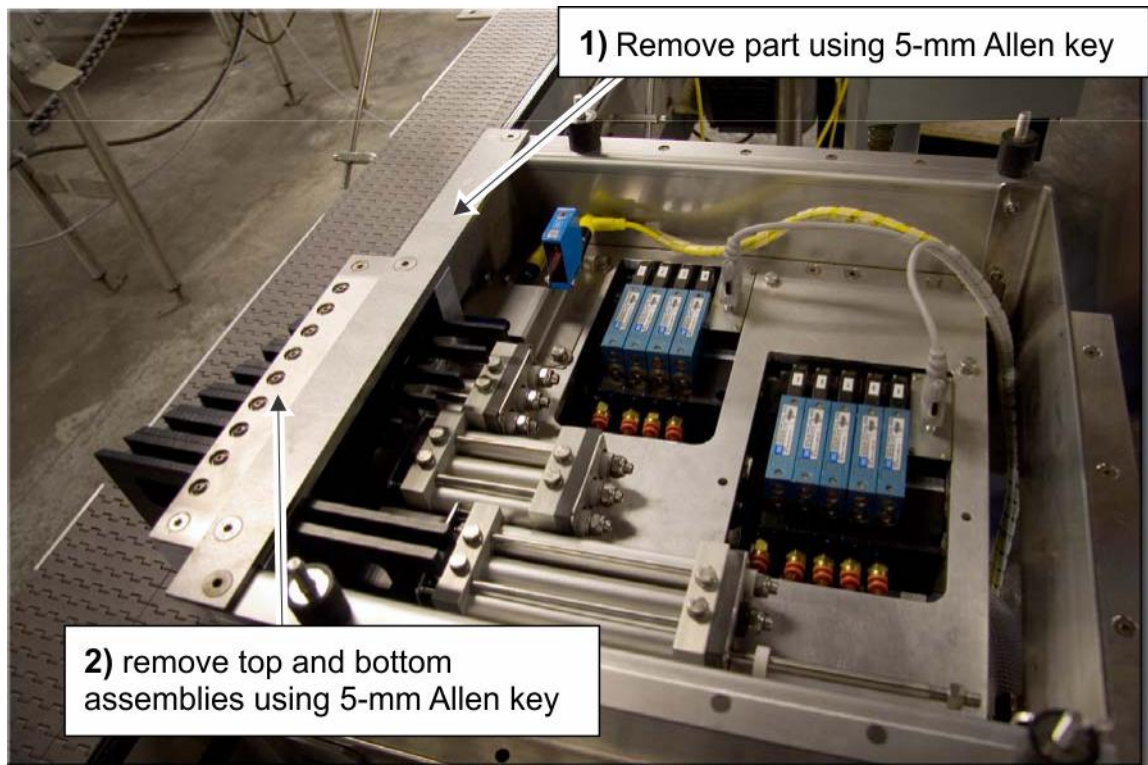

Troubleshooting

This section provides some troubleshooting tips and techniques, based on experience. If the symptom or solution does not solve your problem, then contact **Pressco** (see "**How to Contact Pressco**" on page 51).

Problem	Possible Cause	Solution
Containers unstable at high speeds	Impact with guide rail on conveyor side opposite the segments	Change guide rail position User fewer segments at high speeds Check Maximum Conveying Speed for Segments (on page 26)
	Impact with guide rail separating diverted products from products continuing straight	Move dividing point further downstream, OR Use more segments at that speed
	Encoder cable not properly grounded	Ground encoder cable
Containers destabilized by contact with segments	Diverter not level	Ensure that the diverter is installed properly. The segments must touch a vertical container at the top and at the bottom. This should be verified with the shortest as well as longest segments.
	Insufficient lubrication on conveyor surface	Lubricate conveyor
	Segment surface not clean	Clean conveyor
	Invalid calibration data	If this is a new situation, perform a calibration to ensure that the calibration data used to control the segments reflects the equipment's current condition. BUT do not calibrate dirty equipment as the data will no longer be valid after it is cleaned. Clean the equipment instead. See Segment Calibration (on page 18)
	Some segments seem to knock some bottles over as they extend.	Check Segment Extension and Retraction Times (on page 24)
	Extended segments form too steep a curve for the container.	This could be the case if it is a new installation or a new product. Several segment types are available.
Calibration procedure will not execute at all	Segment detection photocell signal not received	Manually operate the segments. Move all segments forward and observe the photocell signal: it should change state. See Segment Check (on page 15)
Calibration procedure starts but does not complete	At least one segment is not detected by the segment detection photocell	In manual mode, extend all segments. The photocell signal should change. Segment Check (on page 15) Retract one segment and extend it again. Repeat with each segment; the photocell signal should change each time.

Chapter 6

Reject Logic Module (optional)

The Reject Logic Module (70771) takes in the result signals of three different lanes and produces one set of results: Pass or Reject. In this case, the results are being sent to a diverter.

For a drawing that shows the connection from the Intellispec system to the Reject Logic Module to the Diverter, see *Results Connection to Diverter* (on page 11).

Why the Reject Logic Module is Required

In certain applications, there are multiple inspections that take place in series on a production conveyor. These applications can tolerate no slippage, which requires the part detect sensor to be placed very close to the snap point. Due to this, one part detect sensor will not do for all the inspections, and so the inspections must be configured as separate lanes. The diverter cannot handle multiple sets of results for the same bottle, so the Reject Logic Module was designed to resolve the three sets of results into one set of results and send to the diverter.

Operation

The module consists of the following, all enclosed in a stainless steel enclosure:

- DC power supply
- Circuit protection
- PLC
- Touch screen interface

The reject signals of three inspections (X-ray, Label inspection, and FHCP3X) are tied into the PLC inside the Reject Logic Module. In addition, there is a Sync sensor mounted on the line that also ties into the PLC. This sensor is used to establish a physical position on the line where the results of all inspections must be sent. Because the signals must all be timed to arrive within a range of about 8 to 18 msec prior to the sync sensor, you can select a **Timing Setup mode** (on page 40) through the touch screen. In this procedure, you run one bottle through the inspections and then look at the screen. From the timing results, adjust the reject delay so that the results fall within the required window. Once timing is correct, choose **Production mode** from the touch screen, and the system is ready to run.

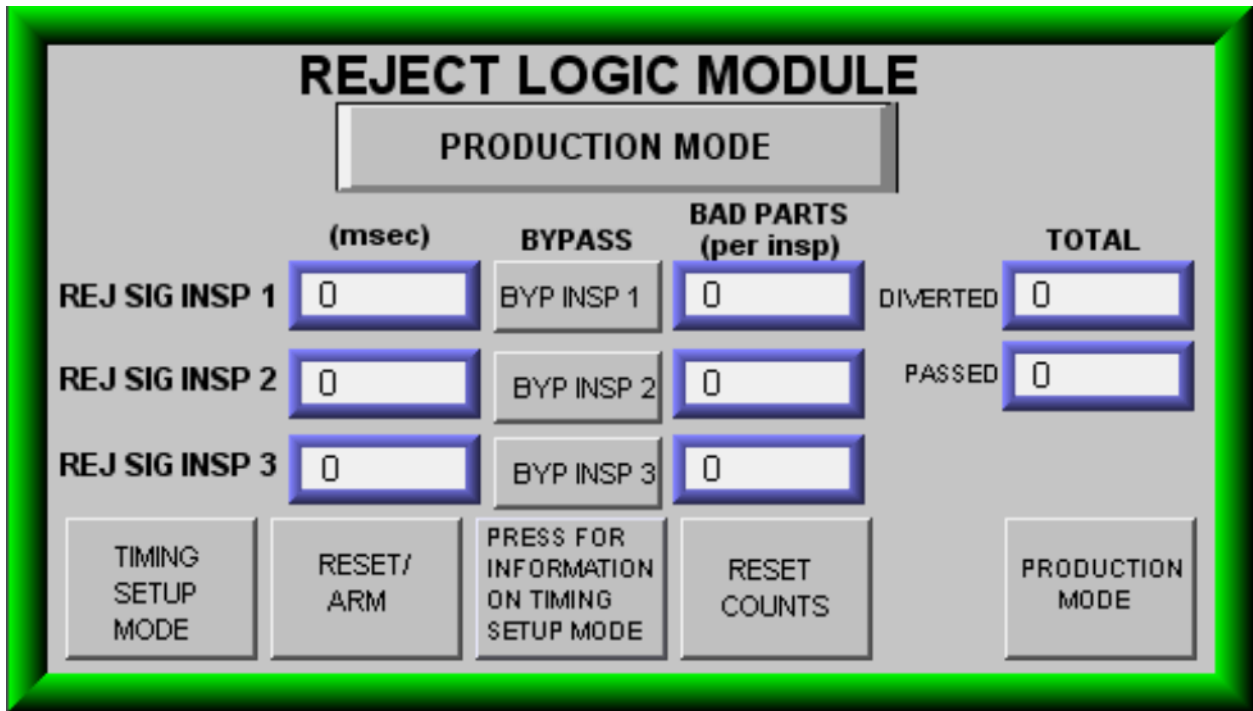

Timing Setup Mode

❖ *Note: this information is displayed on the Reject Logic Module screen for your convenience.*

This mode is used to synchronize the timing of the Reject Signals of all three inspection systems with the Sync sensor. The naming convention is such that the bottle will first pass through Rej Sig Insp 1, then Rej Sig Insp 2, then Rej Sig Insp 3.

The bypass mode is used to omit a lane from the Timing Setup procedure.

➤ **To run Timing Setup Mode:**

1. Place a bottle on the line that will produce a reject for all inspection systems.
2. Make sure all inspection systems are Online, and run a bottle through. The results on the screen are displayed in msec.
 - A **negative** value means the result occurred before the Sync sensor. This is the desired result.
 - A **positive** value means the result occurred after the Sync sensor.
3. Make adjustments to the appropriate Reject Delay signal, press the **Reset/Arm** button, and run the bottle through again.

4. Repeat this process until the values are within the range of [-8] to [-18] msec for all speeds used to run production.
5. Once complete, press the **Production Mode** button to go into production mode.

Chapter 7

Wiring Diagrams

Diverter Wiring page 2a of 5

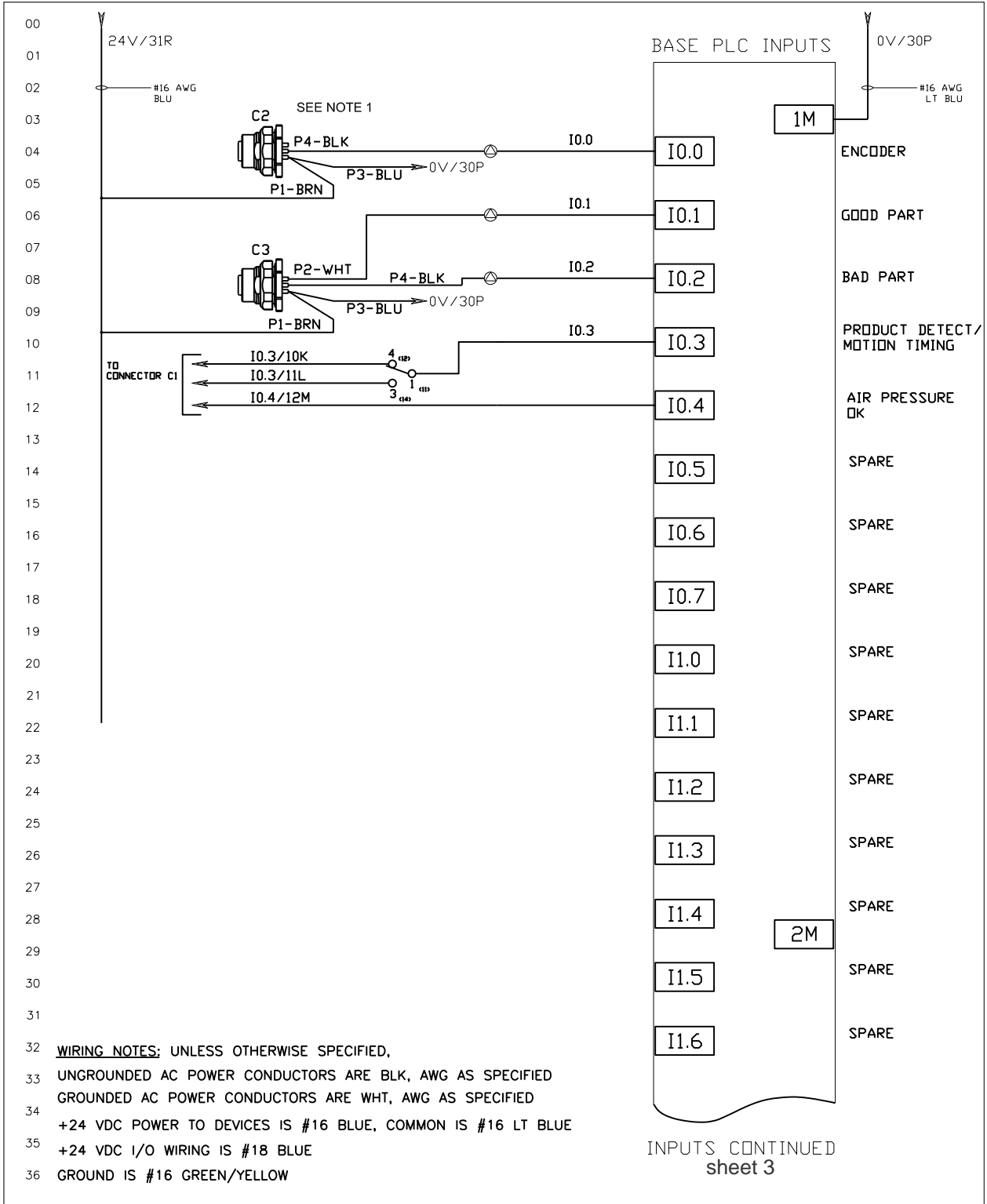

Diverter Wiring page 2b of 5

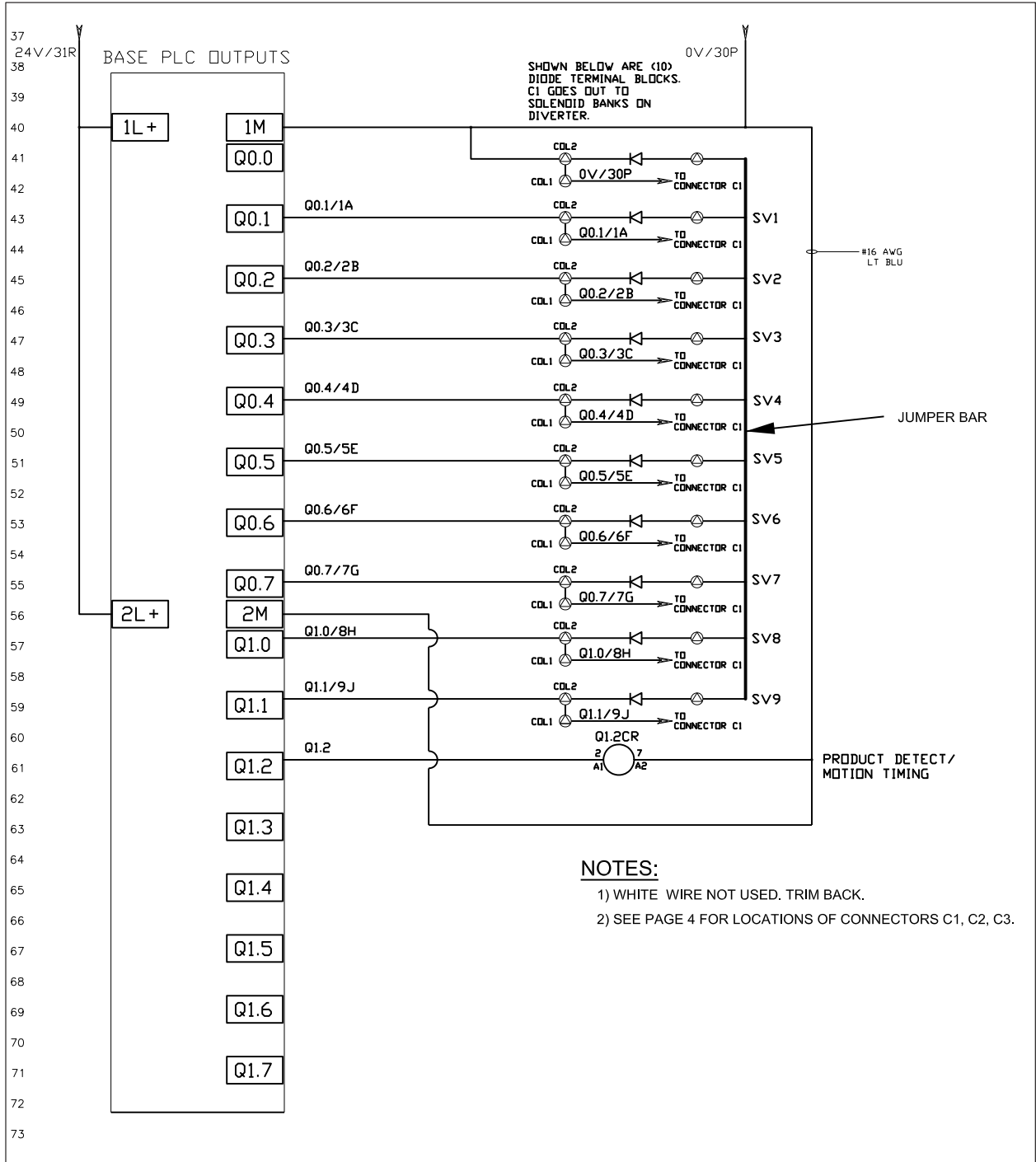

Diverter Wiring page 3 of 5

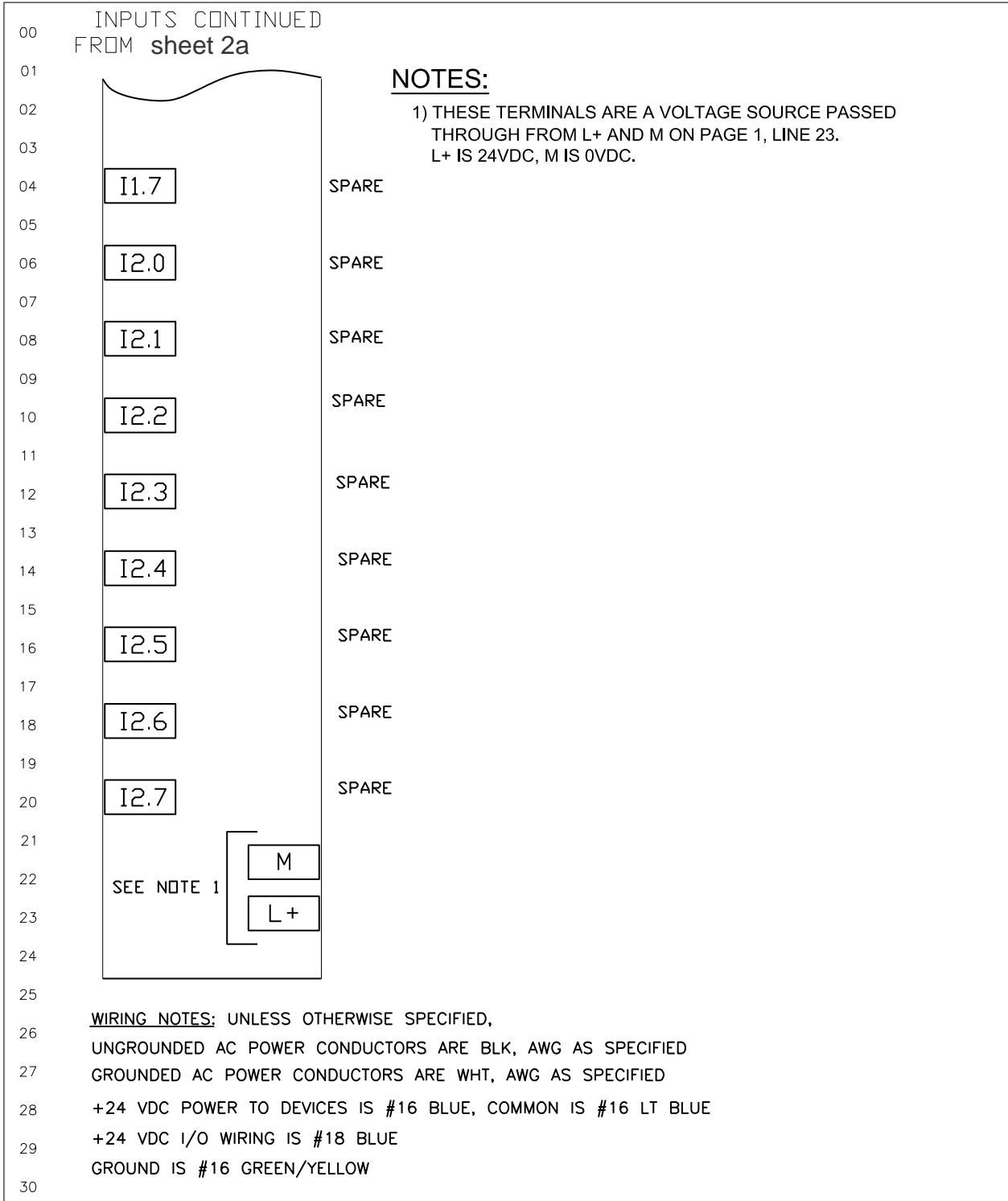

NOTES:

1) THESE TERMINALS ARE A VOLTAGE SOURCE PASSED THROUGH FROM L+ AND M ON PAGE 1, LINE 23. L+ IS 24VDC, M IS 0VDC.

Diverter Wiring page 4 of 5

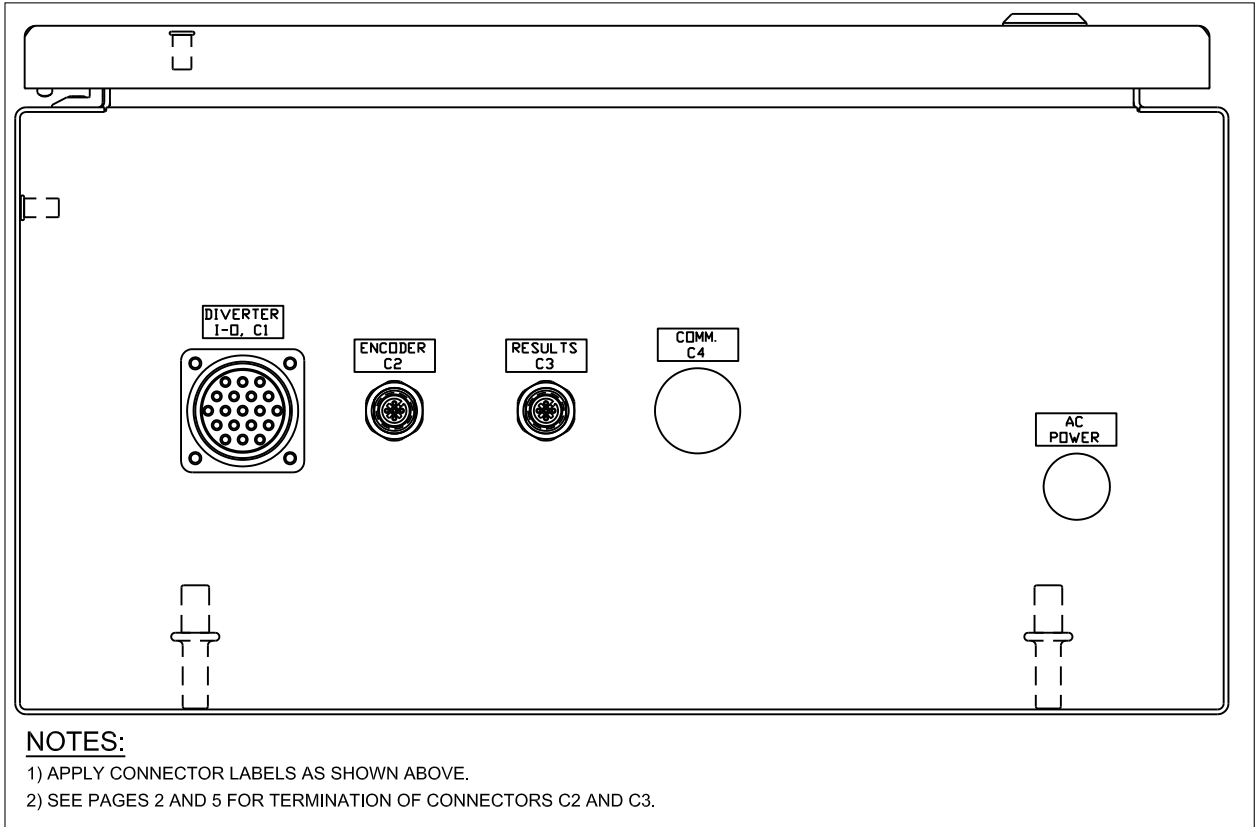

Diverter Wiring page 5a of 5

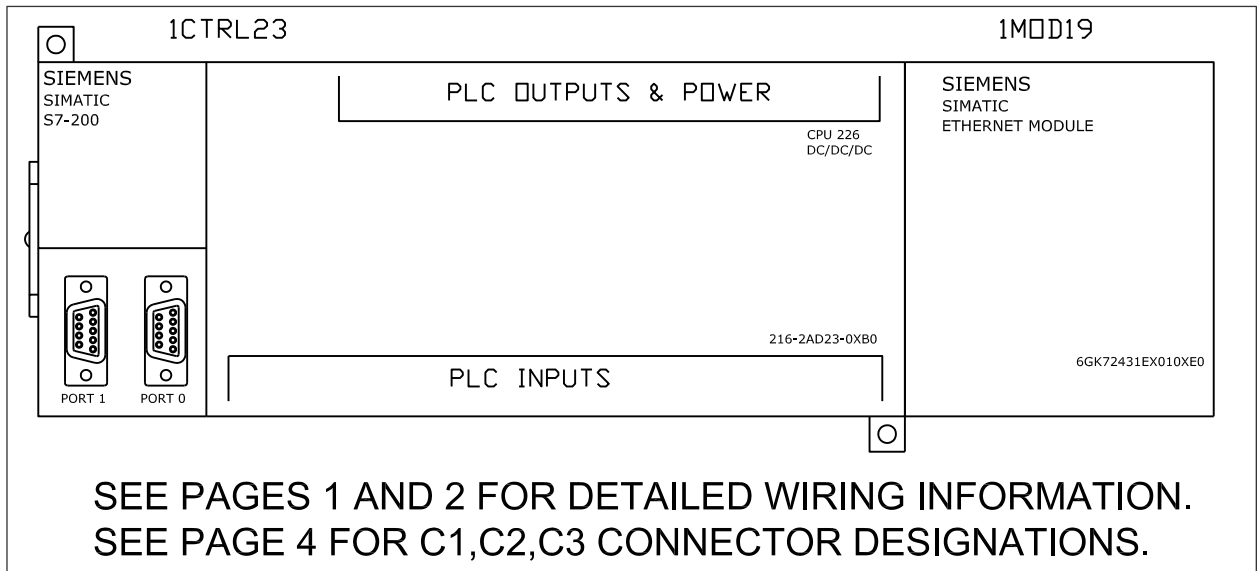

Chapter 8

How to Contact Pressco

24/ 7 Customer Support:

+1 440-498-2000

E-mail:

dispatch@pressco.com (*mailto:dispatch@pressco.com*) or *techsupport@pressco.com*
(*mailto:techsupport@pressco.com*)

Customer Service Fax:

+1 440-498-4761

Mailing Address:

Pressco Technology Inc. 29200 Aurora Rd. Cleveland, OH USA 44139-1847

Main Phone:

+1 440-498-2600

Web Site:

www.pressco.com (*http://www.pressco.com*)

Business Hours:

Monday - Friday, 8:00am - 5:00pm Eastern Standard Time

Index

A

AIR SUPPLY • 12
ALTERNATE MODE • 29
AUTHORIZED USERS • 8

B

BOTTLE DETECT SENSOR AND REFLECTOR • 13
BOTTLE DISTANCE AND WIDTH • 22
BOTTLE SETUP • 21

C

CONTROL SYSTEM • 15

D

DIVERTER INTERFACE • 15
DIVERTER WIRING PAGE 1 OF 5 • 44
DIVERTER WIRING PAGE 2A OF 5 • 45
DIVERTER WIRING PAGE 2B OF 5 • 46
DIVERTER WIRING PAGE 3 OF 5 • 47
DIVERTER WIRING PAGE 4 OF 5 • 48
DIVERTER WIRING PAGE 5A OF 5 • 48
DIVERTER WIRING PAGE 5B OF 5 • 49

E

EDIT PRODUCT DATA MENU • 21
EDIT PRODUCT DATA MENU 2/3 • 24
EDIT PRODUCT DATA MENU 3/3 • 26
ELECTRICAL CONNECTIONS • 9
ENCODER CONNECTION TO DIVERTER • 10
ENCODER PARAMETERS • 17

H

HOW TO CONTACT PRESSCO • 51

I

I/O CHECK • 14
I/O CHECK MENU • 14
INSTALLATION AND INITIAL CHECKS • 9
INTENDED USE • 4

L

LANING MODE • 29
LIFTING HEAVY OBJECTS • 7

M

MAIN MENU • 14
MAINTENANCE • 33
MAINTENANCE AND TROUBLESHOOTING • 33
MAINTENANCE MENU • 33
MANUAL SEGMENT ACTUATION MENU • 16
MANUALLY DIVERT A PRODUCT • 29
MAXIMUM CONVEYING SPEED FOR SEGMENTS • 26
MISC. PARAMETERS MENU • 17

N

NEW BOTTLE TYPE • 21
NON-INTENDED USE • 5

O

OPERATING INSTRUCTIONS • 29
OPERATION • 39

P

PART CHANGEOVER • 31
PERSONAL PROTECTIVE EQUIPMENT • 5
PERSONNEL SAFETY • 6

R

REJECT LOGIC MODULE (OPTIONAL) • 39
REPLACING CYLINDER SETS • 35
REPLACING METAL GUIDES FOR SEGMENTS • 37
REPLACING SEGMENTS • 34
RESIDUAL RISK • 3
RESULTS CONNECTION TO DIVERTER • 11
RUN BOTTLES - NORMAL OPERATION • 29

S

SAFETY INFORMATION AND MARKINGS • 3
SEGMENT CALIBRATION • 18
SEGMENT CHECK • 16
SEGMENT EXTENSION AND RETRACTION TIMES • 24
SPARE PARTS USAGE • 8

T

TIMING SETUP MODE • 40
TROUBLESHOOTING • 38

W

WARNING SYMBOL • 3
WHY THE REJECT LOGIC MODULE IS REQUIRED • 39
WIRING DIAGRAMS • 43

